

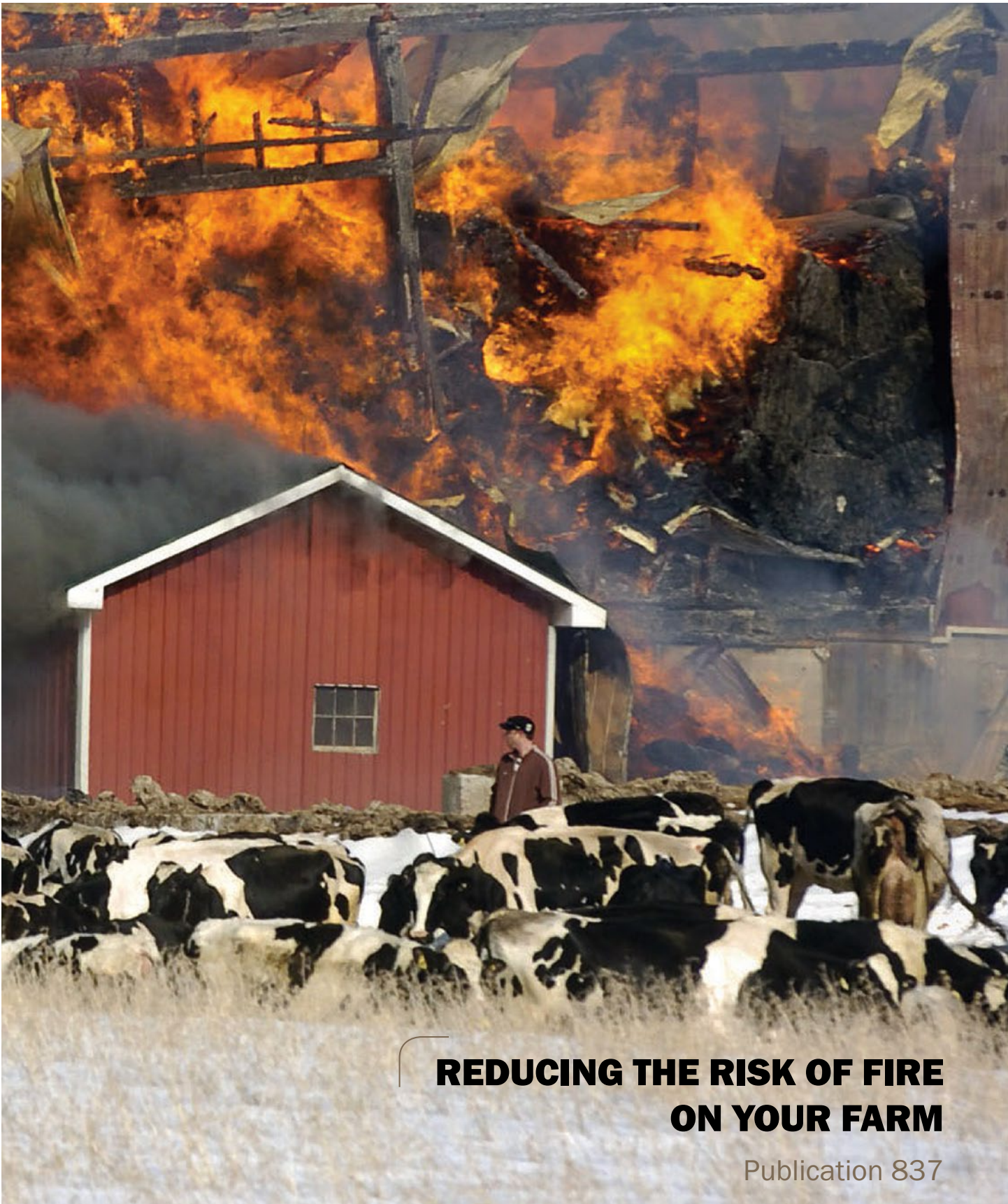

REDUCING THE RISK OF FIRE ON YOUR FARM

Publication 837





**REDUCING THE RISK OF FIRE
ON YOUR FARM**

Publication 837

Editor

Arlene Robertson, Ontario Ministry of Agriculture, Food and Rural Affairs (OMAFRA)

Co-Editors

Dan McDonald, P. Eng., OMAFRA

Daniel Ward, P. Eng., OMAFRA

Acknowledgements

The authors would like to thank the members of the Technical Advisory Committee on Farm Fires (TACFF) for their invaluable contributions to the project.

Thank you to John Johnson, P. Eng., Civil Systems Engineer, OMAFRA (retired) for his expertise and dedication to the project.

Need technical or business information?

Contact the Agricultural Information Contact Centre at 1-877-424-1300 or ag.info.omafra@ontario.ca

A complete listing of all OMAFRA products and services are available at www.ontario.ca/omafra

To obtain copies of this or any other OMAFRA publication, please order:

- Online at www.serviceontario.ca/publications
- *By phone through the ServiceOntario Contact Centre*
Monday to Friday, 8:30 AM to 5:00 PM
 - 416-326-5300
 - 416-325-3408 (TTY)
 - 1-800-668-9938 Toll-free across Canada
 - 1-800-268-7095 TTY Toll-free across Ontario
- *In person at ServiceOntario Centres across Ontario*

Disclaimer

This document is intended for informational purposes only. This document is not intended to provide engineering, legal or other advice. Farmers are advised to consult their own professional engineer or lawyer as applicable to determine the best course of action or legal requirements applicable to their individual farm.

Published by the Ministry of Agriculture, Food and Rural Affairs

© Queen's Printer for Ontario, 2011

Toronto, Canada

ISBN 978-1-4435-5601-9

03-11-3M

Front cover photo: ©2010 Waterloo Region Record, Ontario, Canada

Aussi disponible en français.

Preface

In recent years, fires in Ontario farm buildings have become an increasing concern resulting in losses of more than \$30 million per year. Additional losses to the farm operation include equipment, livestock or poultry lost in the blaze, business interruption, loss of production and extreme stress on the farm family. Although there are fire risks to the home, this document focuses on farm buildings. The growth of larger-scale farming operations has increased the need to address this problem as the financial cost to replace these larger facilities has increased.

Operators need to perform a risk assessment of their farm buildings to consider the operational impact a fire could cause on their farm. As part of the risk assessment, direct specific attention toward the safety of family and employees, and the level of compliance with Codes requirements. All parties involved with designing, constructing and operating farm buildings must understand the importance of following best management practices to protect these large investments and the people working in the facilities.

In 2007, the Ontario Ministry of Agriculture, Food and Rural Affairs (OMAFRA) struck a Technical Advisory Committee on Farm Fires (TACFF) to address the fire safety risks. The purpose of the committee was to reduce the potential for life and property loss by identifying the regulatory requirements and best management practices in the industry.

Members of the committee include:

- Building officials
- Canadian Farm Builders Association
- Electrical Safety Authority
- Farm building contractors and farm building design engineers
- Insurance industry
- Ontario Association of Fire Chiefs
- Ontario Ministry of Agriculture, Food and Rural Affairs
- Ontario Ministry of Municipal Affairs and Housing
- Ontario Office of the Fire Marshal
- Ontario Pork





Introduction

The guide examines the major causes of farm building fires and what can be done to reduce the associated risks. The concepts of fire safety and how they are applied are covered. Strategies are also discussed, using best management practices, to reduce the impact on property and business in the event that a fire does occur.

Reducing the Risk of Fire on Your Farm was developed for consideration in relation to farm buildings such as livestock barns, grain and equipment storage facilities, and other similar farm buildings of low human occupancy. The recommendations pertain to both existing and new construction, supplementing the applicable requirements of the National Farm Building Code of Canada, 1995, (NFBCC) as referenced by Ontario's Building Code (the Building Code), a regulation made under the *Building Code Act, 1992*. The NFBCC establishes minimum requirements for fire protection of farm buildings of low human occupancy.

The *Building Code Act, 1992* requires that a building permit be obtained before any construction, renovation or change of use is undertaken. Using this guide does not relieve the operator from compliance with the prescribed administrative process or the technical requirements in the NFBCC. This guide is intended to explain the principles and concepts of fire safety, and how they relate to the farm and farming practices.

There are other Codes and regulations to be respected when building, renovating or operating farm buildings. For example, the Ontario Electrical Safety Code requires that all electrical equipment used in Ontario display a Canadian electrical approval stamp – Canadian Standards Association (CSA) and Underwriters Laboratory of Canada (ULC). If liquid or gaseous petroleum products are used on the farm, there are Codes specifying requirements for the safe storage and handling of these products. These Codes are enforced by the Technical Standards and Safety Authority (TSSA). The operator is responsible for understanding these requirements as well as other governing regulations on the farm.

The guide is intended to highlight best management practices. To further reduce risk, there are instances where requirements greater than those contained in the NFBCC are specified. Do not rely on *Reducing the Risk of Fire on Your Farm* as a substitute for specialized legal or professional advice in connection with any particular matter. The user is solely responsible for any use or application of this guide. Although the guide has been carefully written, the authors, committee and the government of Ontario do not accept any legal responsibility for the contents of the guide or for any consequences, including direct or indirect liability, arising from its use.



CONTENTS

1.0 Leading Causes of Farm Building Fires	1
Mechanical/Electrical Failure	2
Misuse of Ignition Source or Igniting Equipment	3
Design, Construction or Maintenance Deficiency	3
Other Factors that Contribute to the Impact of Fires	4
2.0 Preventative Maintenance to Reduce the Risk of Fire	5
General Operating Practices	5
Electrical Systems	6
Mechanical Systems	9
Heating Appliance Systems	10
3.0 Preventing Fire Spread	13
Fire Separation	13
Fire Compartments	16
Fire Stopping	18
Spatial Separation	23
Flame Spread	24
Electrical Code Considerations	27
Heating System Considerations	29
4.0 Reducing the Impact of Fire	31
Detection and Suppression Systems	31
Fire Department Access	32
Water Supply for Fire Fighting	35
Evacuation	37
5.0 Assessing Your Risk	43
Summary	44

1.0 Leading Causes of Farm Building Fires

The Office of the Fire Marshal manages a database on all fire and explosion occurrences in Ontario. Data reported by fire departments for 2004 – 2007 were analyzed for occurrences involving farm buildings to identify common causes and what can be learned to reduce them. Figure 1 shows a very large swine facility after it was destroyed by fire, in less than one hour.



Figure 1.0. This large swine barn was completely destroyed by fire.
(Photo credit: P. Stolk, Farm Mutual Reinsurance Plan)

While the sources of many fires are undetermined due to significant fire damage, there are three leading causes of identifiable farm fires, as reported by fire services.

Mechanical/electrical failure

- short circuit or ground fault in electrical equipment
- failure of the built-in automatic controls in mechanical equipment or system

Misuse of ignition source or igniting equipment

- improperly discarded smoker's material
- ignition source left unattended
- smoking where flammable vapours are present
- improper use of extension cords (e.g. overloaded circuit, multiple strings in sequence)

Design, construction or maintenance deficiency

- improperly constructed building feature or system
- improperly installed object such as a heating appliance that is too close to combustible building features
- improper maintenance such as failure to remove accumulation of combustible dust or debris, which is then ignited by heating appliances, process equipment or electrical equipment
- faulty product design causes a fire even when the product is installed and used correctly

Mechanical/Electrical Failure

The insurance industry, in association with the Electrical Safety Authority (ESA), reviewed additional information on mechanical and electrical failures leading to barn fires. They identified the corrosive environment found inside confined livestock barns as the leading cause of degradation or failure of electrical equipment. The degradation is typically corrosion of the exposed metal components (e.g. wires, connections, etc.). The corrosion increases the resistance at these points causing a reduction in the flow of electricity through the circuit. The increased resistance results in more of the electrical energy being converted to heat (Figures 1.1 and 1.2). As the corrosion levels continue to increase, the heat generated rises to the ignition temperature of the materials surrounding the equipment. The decay can occur over a short period of time. Evidence of corrosion has been observed in barns less than five years after construction.

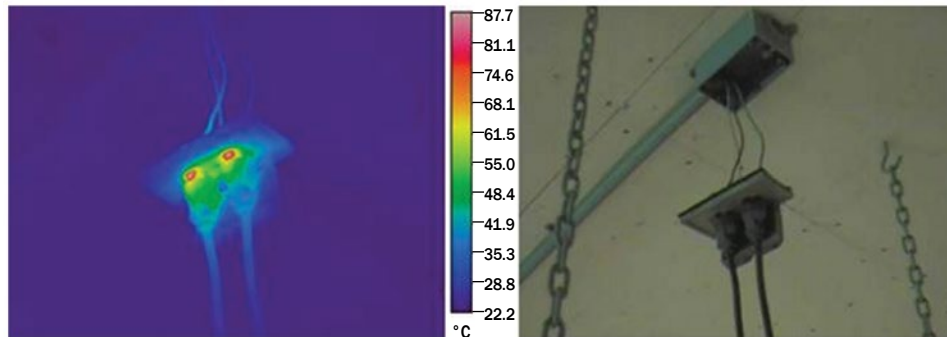

Figure 1.1. Thermographic picture of an electrical receptacle in a livestock barn.
 (Photo credit: R. Drysdale, Farm Mutual Reinsurance Plan)

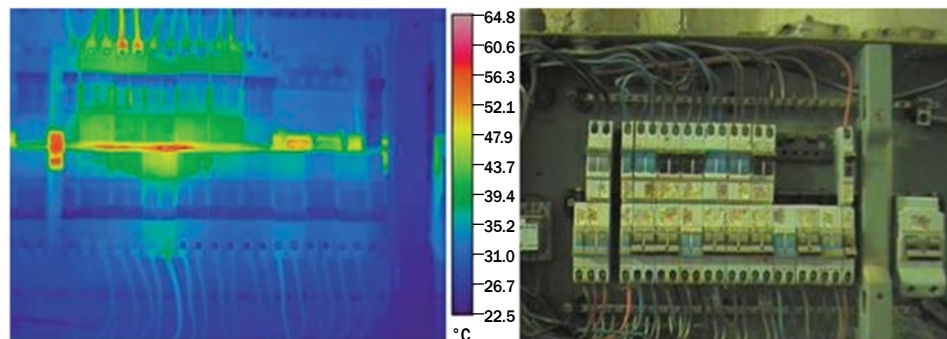

Figure 1.2. Thermographic picture of an electrical panel in a livestock barn.
 (Photo credit: R. Drysdale, Farm Mutual Reinsurance Plan)

Misuse of Ignition Source or Igniting Equipment

A commonly reported cause of fires in farm buildings is the misuse of equipment (i.e. arc welders, cutting torches or grinders) in the presence of combustible materials or gases without the proper safeguards. The careless use of smoker's materials (i.e. cigarettes, matches, pipes) continues to be a common cause of fires. Fires reported in this group reflect human error and are preventable with best practice operating procedures (Figure 1.3).



Figure 1.3. Grinding operation taking place in the presence of combustible materials. Use this type of equipment outside the barn and away from combustibles, or put safeguards in place to reduce the risk of accidental ignition.

Design, Construction or Maintenance Deficiency

Improperly designed, installed or maintained building systems are another common cause of farm building fires. This includes heating equipment, lighting systems, process equipment and electrical distribution. For example, heat shields for a suspended radiant tube heater may become displaced with the use of a high pressure washer. Without the shields properly in place, the underside of the ceiling becomes too hot and increases the potential for ignition and fire (Figures 1.4 and 1.5). Although the design and installation of the equipment is correct, a maintenance deficiency would be identified as the cause of the fire.



Figure 1.4. Radiant tube heater with heat shield displaced. Note charring on the ceiling.

(Photo credit: R. Drysdale, Farm Mutual Reinsurance Plan)



Figure 1.5. Radiant tube heater lacking heat shield. Note close proximity to combustibles (wood ceiling and conduit).
(Photo credit: R. Drysdale, Farm Mutual Reinsurance Plan)

Other Factors that Contribute to the Impact of Fires

In addition to looking at the causes of fire, it is important to review other factors that contribute to fire growth and the magnitude of the losses. An ignition source must be close to combustible materials for fire to start. Combustible materials cannot be totally avoided on the farm, but reducing their use in construction and establishing good housekeeping practices goes a long way in reducing fire growth. The use of fire compartments is an effective design strategy to contain a fire and prevent total building destruction. To be effective, keep fire compartments in good condition, including the proper operation of fire doors. Early detection and fire response are key to reducing the magnitude of farm fires. Many of these concepts and recommended considerations are covered in this guide.

2.0 Preventative Maintenance to Reduce the Risk of Fire

There are several operational and maintenance practices that farm operators can use to reduce the risk of fires on farm.

General Operating Practices

- Do not allow smoking in farm buildings. Restricting access to farm buildings keeps people out who don't know or respect these rules.
- When repairing fixed or stationary equipment inside a farm building (livestock penning, stabling, etc.) with ignition source equipment (welders, cutting torches or grinders), ensure that:
 - fire extinguishers are located in the work area
 - all combustible materials are removed from the work area
 - the site is well ventilated to reduce the concentration of combustible gases present

Establish a fire watch during the work and for a period of time following completion. Gas detection devices are available if accurate gas concentration levels are required.

- Establish good housekeeping practices. Eliminate clutter inside and outside the buildings. Keep grass and weeds mowed around buildings. These measures reduce the risk of fire spread and improve the effectiveness of suppression activities.
- Be careful when pressure washing inside a farm building. The high pressure water can physically damage equipment and allow deep water penetration into unwanted areas such as electrical panels, heater controls, etc.
- Grain handling and feed preparation activities generate dust which presents an explosion and/or fire hazard. Vent these areas and provide a fresh air supply. Properly protect electrical fixtures and use totally enclosed, fan-cooled motors. Good housekeeping practices are critical to limit combustible materials from this area.
- Ensure all liquid fuel and propane storage areas are located according to applicable Codes (adequate separation distance from fixed ignition sources, etc.). If the storage tanks are exposed to vehicle traffic, install protection (i.e. bollards or equivalent) around the storage tanks to reduce risk of damage from vehicle collisions (Figure 2.1).



Figure 2.1. On-farm fuel storage with vehicle protection (bollards).
(Photo credit: FS Partners)

- Install all electrical equipment associated with fuel storage (i.e. electric fuel pump) according to the Ontario Electrical Safety Code.

Electrical Systems

The combination of a humid (wet) and corrosive environment is harmful to exposed electrical equipment (plug ends, unsealed junction points, etc.). Excessive corrosion increases the equipment’s electrical resistance and results in increased heat production, the suspected ignition source in a number of barn fires. Thermographic imaging exposes the problem, primarily in swine buildings, however the issue is also seen in poultry and other livestock facilities. Review and follow these best practices relating to the use and maintenance of electrical equipment.

- On a yearly basis, have a licensed electrical contractor inspect all electrical equipment within the barn. Focus particular attention on cord caps (ends), ceiling mounted outlets, light fixtures (Figure 2.2) and electrical panels located within the animal areas.



Figure 2.2. Light fixture in a dairy barn that caught fire due to the presence of a bird’s nest (proximity of combustibles).
(Photo credit: R. Drysdale, Farm Mutual Reinsurance Plan)

- Complete a yearly thermographic inspection of the entire electrical system when the barn is at its peak electrical demand (e.g. summer for swine and poultry). Many insurance companies now offer this value added service for their policyholders. Make any necessary repairs to eliminate identified hot spots (Figure 2.3).

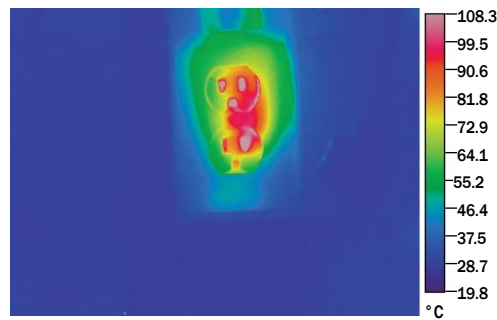

Figure 2.3. Thermographic image of an electrical outlet in a barn discovered during an annual inspection. Note the hotspots (red) at greater than 100 °C (212 °F).

(Photo credit: R. Drysdale, Farm Mutual Reinsurance Plan)

- The Ontario Electrical Safety Code permits the use of wiring for damp locations in farm buildings housing livestock or poultry when the area has adequate ventilation. For more information on ventilating livestock buildings, see OMAFRA Publication 833, *Ventilation for Livestock and Poultry Facilities*, www.serviceOntario.ca
- Replace older wiring that passes through the walls or other concealed building spaces with wiring installed in conduit.
- Have a licensed electrical contractor perform all electrical work within the building to ensure it is done safely and meets the requirements of the Ontario Electrical Safety Code. All electrical installations must be inspected by the Electrical Safety Authority (ESA).
- Properly secure wiring enclosure covers to minimize the entry of corrosive gases and moisture. Replace damaged or deteriorated parts.
- Do not store flammable and/or combustible material underneath or around the electrical panels.
- Ensure a minimum of 1 m (3 ft) of clear access space in front of each electrical panel.
- Repair all damaged or malfunctioning fixtures or equipment as soon as practical.
- Completely remove or physically disable all abandoned or malfunctioning wiring within the barn. Removing the fuse or turning off the breaker is not a good practice, or long-term solution, and can lead to dangerous situations if the circuit is reactivated by accident.
- Heat lamps are a common source of fire. When heat lamps are required, protect the immediate area with non-combustible sheathing (concrete board, concrete, steel, tile, etc.). Keep the area around the heat lamp clear of clutter or bedding materials that could catch fire. Only use heat lamps with the CSA or ULC label. Figures 2.4a and 2.4b show examples of incorrect and correct uses of heat lamps.



Figure 2.4a. Example of incorrect use of a heat lamp.

The following situations are incorrect uses for a heat lamp:

- lamp suspended using baler twine (combustible material)
- incorrect wiring, electrical cords are knotted together
- lamp suspended too close to bedding (combustible)
- animals have access to lamp



Figure 2.4b. Example of improved use of a heat lamp.

These situations are correct ways to use a heat lamp:

- lamp suspended using chain (non-combustible material)
- plug connection is not knotted allowing for easy separation
- lamp suspended at a correct height to bedding
- limit large animal access to lamp

Mechanical Systems

Mechanical systems such as ventilation fans, feed auger motors, milk cooling equipment and generators break down or wear out with time. Regular maintenance reduces the risk of overheating and decreases the risk of fire.

- Inspect all motors and mechanical equipment according to the manufacturer's maintenance schedule (minimum, yearly) for evidence of wear, overheating, etc. Repair or replace equipment as required.
- Ventilate mechanical rooms to reduce the risk of motors (standby generators, refrigeration compressors, milk vacuum pumps, etc.) overheating during normal operation.
- Properly shield exhaust pipes from standby generators or vacuum pumps, that pass through a wall or ceiling, to reduce the risk of the building overheating and possibly igniting (Figure 2.5). Figure 2.6 shows the potential risk for fire due to the lack of a heat shield ring.



Figure 2.5. Proper installation of the exhaust pipe through the wall. Note the heat shield ring around the exhaust pipe.

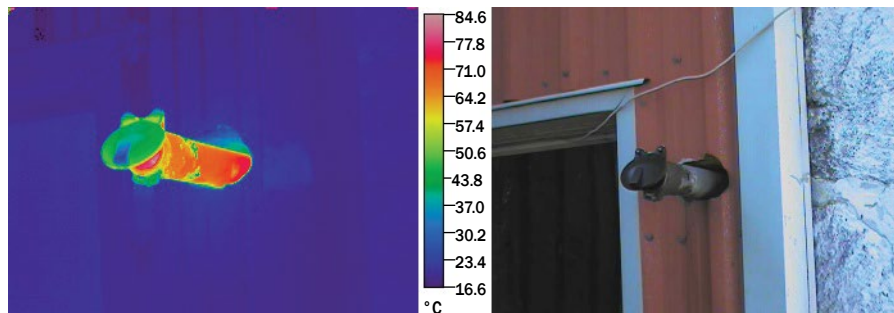

Figure 2.6. Thermographic image of an exhaust pipe. Note the lack of heat shielding where the pipe passes through the wall.

(Photo credit: R. Drysdale, Farm Mutual Reinsurance Plan)

- For belt-driven fans, regularly inspect the belts to ensure they are not damaged or missing. Also ensure the fan blade assembly spins freely and does not hit the fan housing.
- Dust and debris build up over time and can cause fan blades to stop turning, resulting in overheating of the fan motor. Remove dust and debris from fan motors and blades to reduce the risk of a fire starting (Figure 2.7). This maintenance is especially important in feed rooms and barns housing livestock and poultry.



Figure 2.7. Example of a dirty fan in need of cleaning.

- Have all repairs completed by a qualified individual and ensure all applicable Codes are met.

Heating Appliance Systems

Heating systems are particularly important as they contain an ignition source (i.e. pilot light, igniters) and open flames.

- Complete annual maintenance of all heating devices within the farm buildings. Consult a qualified heating technician for this maintenance. Figures 2.8a and 2.8b show how heating equipment can corrode in a barn with high humidity and corrosive air properties.

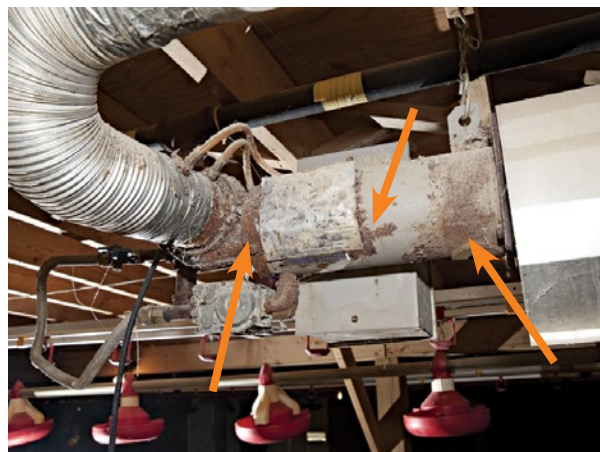

Figure 2.8a. Rear view of a radiant tube heater inside a broiler barn.

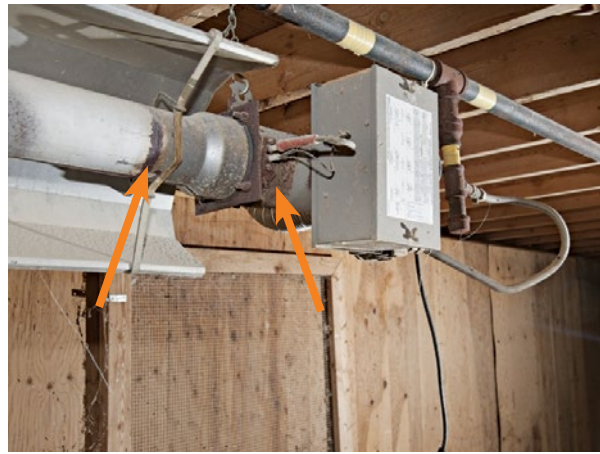

Figure 2.8b. Front view of a radiant tube heater inside the same broiler barn. Corrosion is present.

- Ensure all heat shields are in place for any heating device that requires them. This is especially important for radiant tube heaters (Figure 2.9).



Figure 2.9. Radiant tube heater lacking heat shield. Note close proximity to combustibles (wood ceiling and conduit).

(Photo credit: R. Drysdale, Farm Mutual Reinsurance Plan)



3.0 Preventing Fire Spread

Design Codes and/or standards are minimum requirements established to protect the lives of people and the contents in farm buildings. Codes describe correct farm building materials to use to reduce the number of ignition sources, reduce the rate fire spreads within buildings and establish separation distances for fire spread to other buildings. These Codes are in place because barn layout and construction materials greatly influence the fire risk associated with a given site.

When discussing fire safety, prevention, precautions and procedures are often included. Prevention, as highlighted in this section, deals with ways to prevent the initial source of ignition from spreading and prevent fire from starting in adjacent areas.

Fire Separation

One of the key concepts of fire safety in all buildings, including farm buildings, is to limit the spread of fire throughout a building with a physical barrier, known as a fire separation. A fire separation can be a wall, ceiling or floor of a building (Figure 3.1). Several fire separations are often used in combination to surround a given space and contain fire within it; this space is termed a fire compartment.



Figure 3.1. Example of a fire separation that served its purpose in a swine complex, preventing the fire from spreading to the rest of the barn.

(Photo credit: R. Drysdale, Farm Mutual Reinsurance Plan)

A wall, when put together or constructed in a building, is known as a wall assembly. Similarly, ceilings and floors, once built, are referred to as ceiling and floor assemblies.

Wall, floor and ceiling assemblies of buildings are built in different ways using a variety of construction materials. The way these assemblies are constructed determines how long it will take a fire to burn through the assembly and penetrate from one fire compartment to another. Wall, floor and ceiling assemblies built as required fire separations are usually given a specific fire-resistance rating to meet.

A fire-resistance rating is a measure of the length of time a properly constructed and maintained assembly can withstand fire conditions. In the case of a fire separation, a fire-resistance rating identifies the time for a fire to burn through from one compartment to another (30 minutes, 1 hour, 2 hours, etc.).

Examples of common wall assemblies used as fire separations in farm buildings are shown in Table 3.1. It is important to note that the fire-resistance rating of a construction assembly is for a specific configuration of structural elements. A similar wall component may behave differently if it is located in a ceiling.

Table 3.1. Estimated Fire-Resistance Ratings for Assemblies^{1,2}

Structure	Membranes	Fire-resistance (minutes)
38 mm x 89 mm (2 in. x 4 in.) wood studs, 400 mm (16 in.) on centres (o.c.)	11.0 mm (7/16 in.) Douglas fir plywood, OSB or wafer board (both faces)	30
	14.5 mm (9/16 in.) Douglas fir plywood, OSB or 15.5 mm (5/8 in.±) wafer board (both faces)	35
38 mm x 89 mm (2 in. x 4 in.) wood studs, 600 mm (24 in.) o.c.	11.0 mm (7/16 in.) Douglas fir plywood, OSB or wafer board (both faces) with the stud spaces filled with mineral wool	30
	12.7 mm (1/2 in.) gypsum wallboard (both faces) ³	35
38 mm x 89 mm (2 in. x 4 in.) wood studs, 400 mm (16 in.) or 600 mm (24 in.) o.c.	1 layer of 15.9 mm (5/8 in.) Type X gypsum board on each side*	60
140 mm (5½ in.) hollow concrete blocks (normal weight aggregate)	Block is the membrane	60
190 mm (7½ in.) hollow concrete blocks (normal weight aggregate)		90

¹Additional information on fire-resistance ratings for assemblies is given in Ontario’s Building Code.

²Interior walls are rated from both sides, whereas floors and roofs are rated from below.

³Use gypsum wallboard in farm buildings only in specific locations.

Source: National Farm Building Code of Canada, 1995.

*2006 Building Code – Supplementary Standards SB-3, page 2.

Fire separations must be continuous. Except for openings in the outside face of a building, provide openings in fire separations around a fire compartment with properly rated closures. Use appropriate construction materials to ensure all gaps are fire stopped. In a number of situations where it is not practical to avoid openings, special measures are taken to limit the spread of fire through these openings. See the section on Protection or Closure of Openings in Fire Separations.

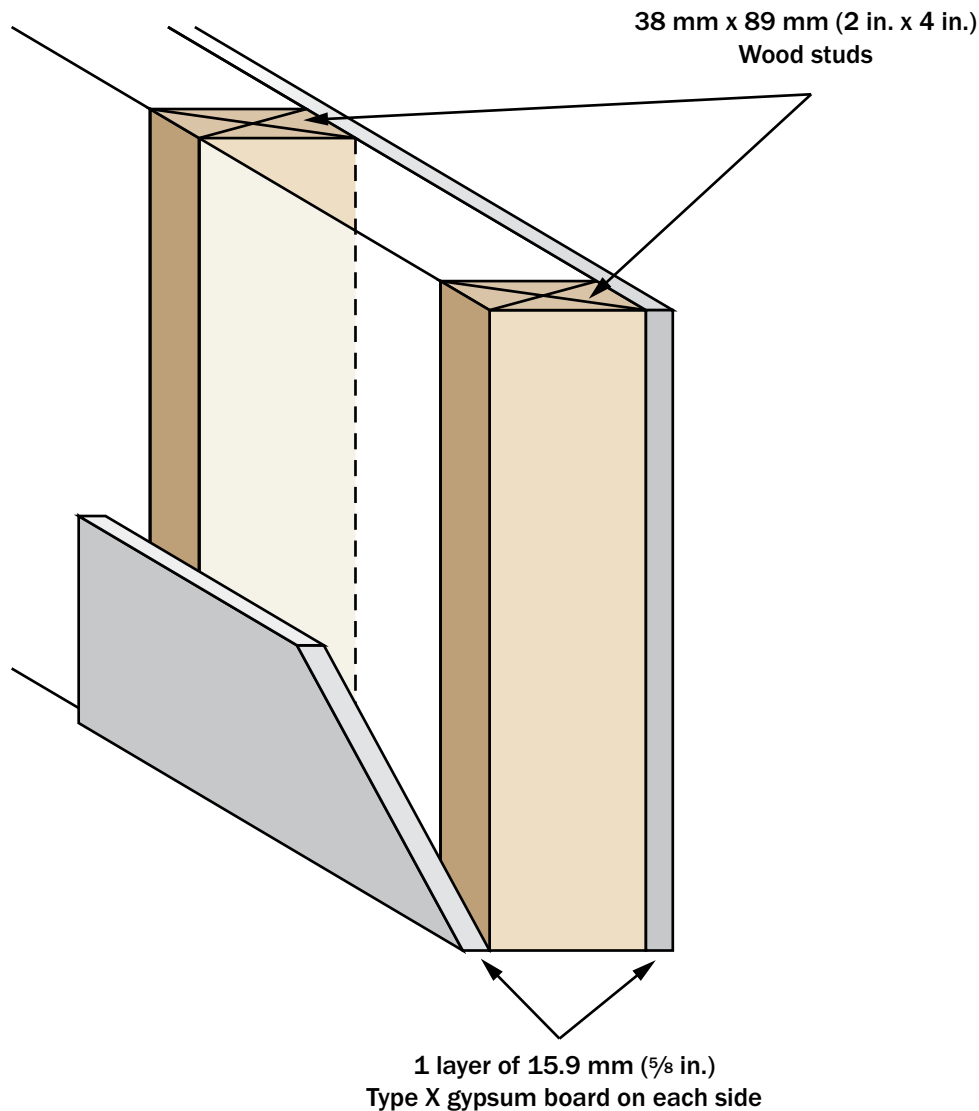

Figure 3.2. Example of a common one hour fire separation. Where drywall is used in high moisture areas, provide a vapour barrier in an appropriate location that protects the drywall.

Containing the electrical/mechanical room in farm buildings is an example of a fire separation that provides a valuable compartment to prevent the spread of fire. Equipment such as standby generators or compressors for refrigeration units can overheat and start a fire. Having a continuous fire separation around this equipment often provides enough time to extinguish the fire before it spreads to the rest of the building causing a total loss of the structure.

With the exception of specific heating and cooling equipment, the NFBC further requires a fire separation with a minimum rating of 30 minutes between fuel-fired appliances, crop drying and equipment repair rooms, and the remainder of the building. The Technical Advisory Committee on Farm Fires (TACFF) recommends increasing these fire separations to one hour for buildings containing liquid fuel storage or highly combustible materials such as hay or straw.

To reduce fire losses and as a best management practice, TACFF recommends paying increased attention to the construction and maintenance of fire separations.

Fire Compartments

A fire compartment is a usable, enclosed space in a building that is separated from all other parts of the building. Many Codes specify maximum compartment sizes, to contain a specific fire risk within an area and protect people in the rest of the building. For the concept to work, compartment boundaries must have an adequate level of fire-resistance. All openings and penetrations through these boundaries require protection with rated closures or fire stops. The level of fire-resistance required depends on many things including the building size and type of occupancy.

The NFBCC does not limit the building size of farm buildings, but specifies that where the floor area exceeds the maximum size (Table 3.2), the building be separated into fire compartments.

Table 3.2. Maximum Floor Areas for Farm Buildings of Low Human Occupancy

Number of Storeys	Maximum Floor Area/Storey
1	4,800 m ² (51,600 ft ²)
2	2,400 m ² (25,800 ft ²)
3	1,200 m ² (12,900 ft ²)

Source: National Farm Building Code of Canada, 1995.

Review existing farm buildings to assess the practicality of reducing fire compartment sizes to conform with building area limits established in Table 3.2.

Consider these sizes when designing new buildings. For a one storey barn, the NFBCC allows a maximum compartment size of 4,800 m² (51,600 ft²). If the building footprint is larger than 4,800 m², the designer’s challenge is to maximize the overall efficiency of the layout and achieve all the safety objectives for compartmentalization.

For example, dividing a large free stall dairy barn, 33 m (110 ft) wide x 198 m (650 ft) long, into two compartments to meet the compartment size requirement would involve erecting a fire separation wall near the midpoint of the 198 m (650 ft) length. Since the cow alleyways and the central feed alleyway run on the long axis of the building, this would result in five large door openings in the fire separation equipped with closure devices (fire doors). This layout could negatively impact equipment and cow traffic, and air movement in the barn (Figure 3.3).

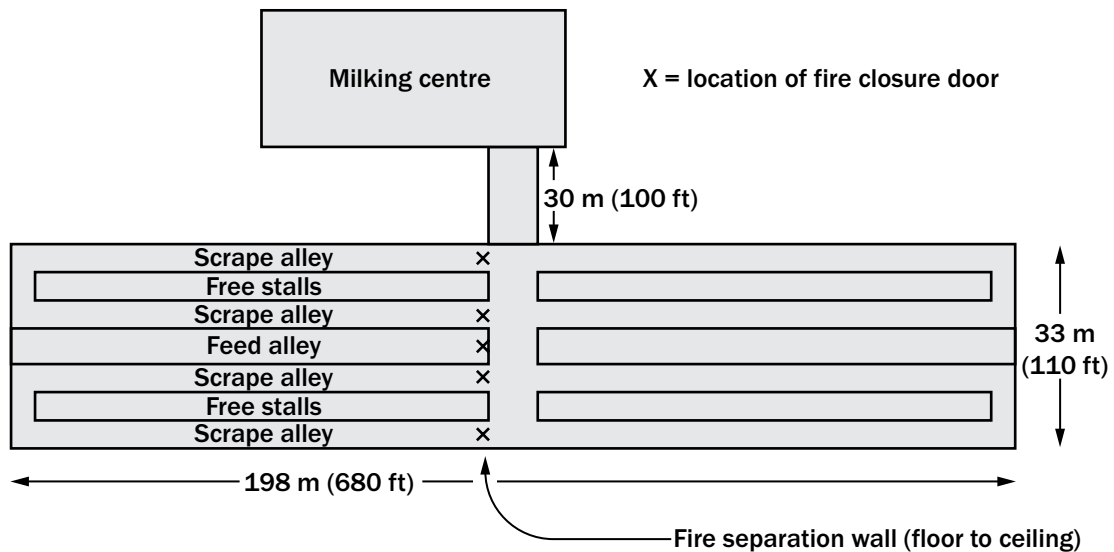

Figure 3.3. A large free stall dairy barn with fire separation wall at the midpoint.

From a fire separation stand point, it is more effective to erect several free stall barns that each measure less than 4,800 m² (51,600 ft²). These barns could be spaced at least 30 m (100 ft) apart and interconnected with hallways to house the animals. One closure device (fire door) located in the middle of each connecting hallway enables the design to meet the fire compartment size requirements, and minimize flow issues associated with cow and equipment traffic, and air movement (Figure 3.4).

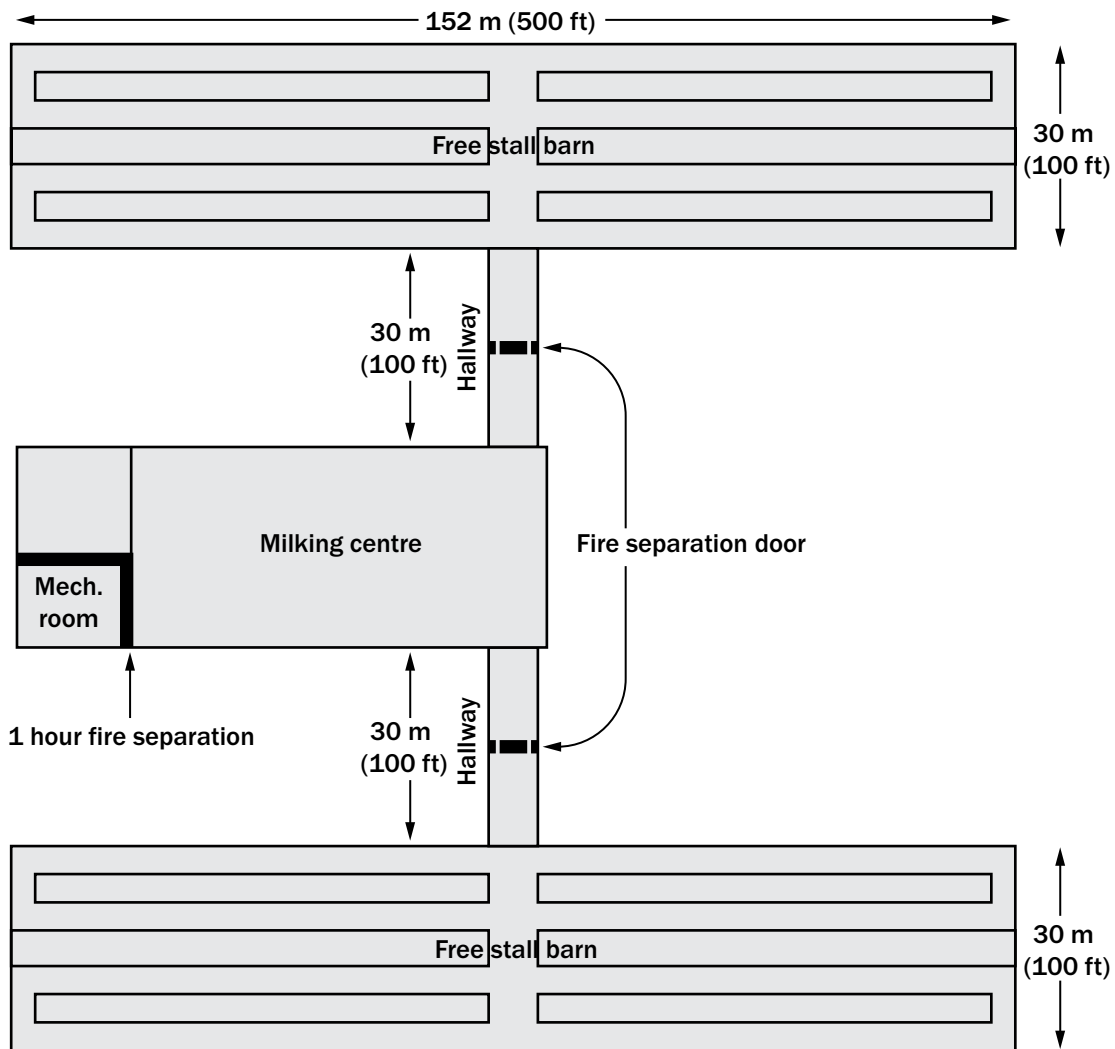

Figure 3.4. The fire compartments formed by several fire separations will slow the spread of fire and provide a better opportunity to fight a fire in this large building complex.

Fire Stopping

Fire stopping is another key concept for fire safety in all buildings, including farm buildings. Fire stops are used to limit the spread of fire throughout a building with a physical barrier in concealed spaces.

Fire stops are usually located within walls, floors, ceilings and in attic spaces. Fire stops are commonly constructed with solid lumber not less than 38 mm thick (1½ in.). Fire stops in concealed spaces should conform to the provisions in the NFBC. As noted in the Ontario Construction Guide for Farm Buildings 2003 at www.orderline.com, fire stops in farm buildings reduce the spread of smoke and flames within concealed spaces, giving people time to escape in the event of fire. Properly installed fire stops also prevent rodents and birds from easy access throughout the same concealed spaces, making the buildings more durable while increasing fire safety. Figure 3.5 shows a typical two storey barn cross-section.

To reduce fire losses, and as a best management practice, TACFF recommends using smaller compartment sizes in farm buildings with properly constructed fire walls and separation distances.

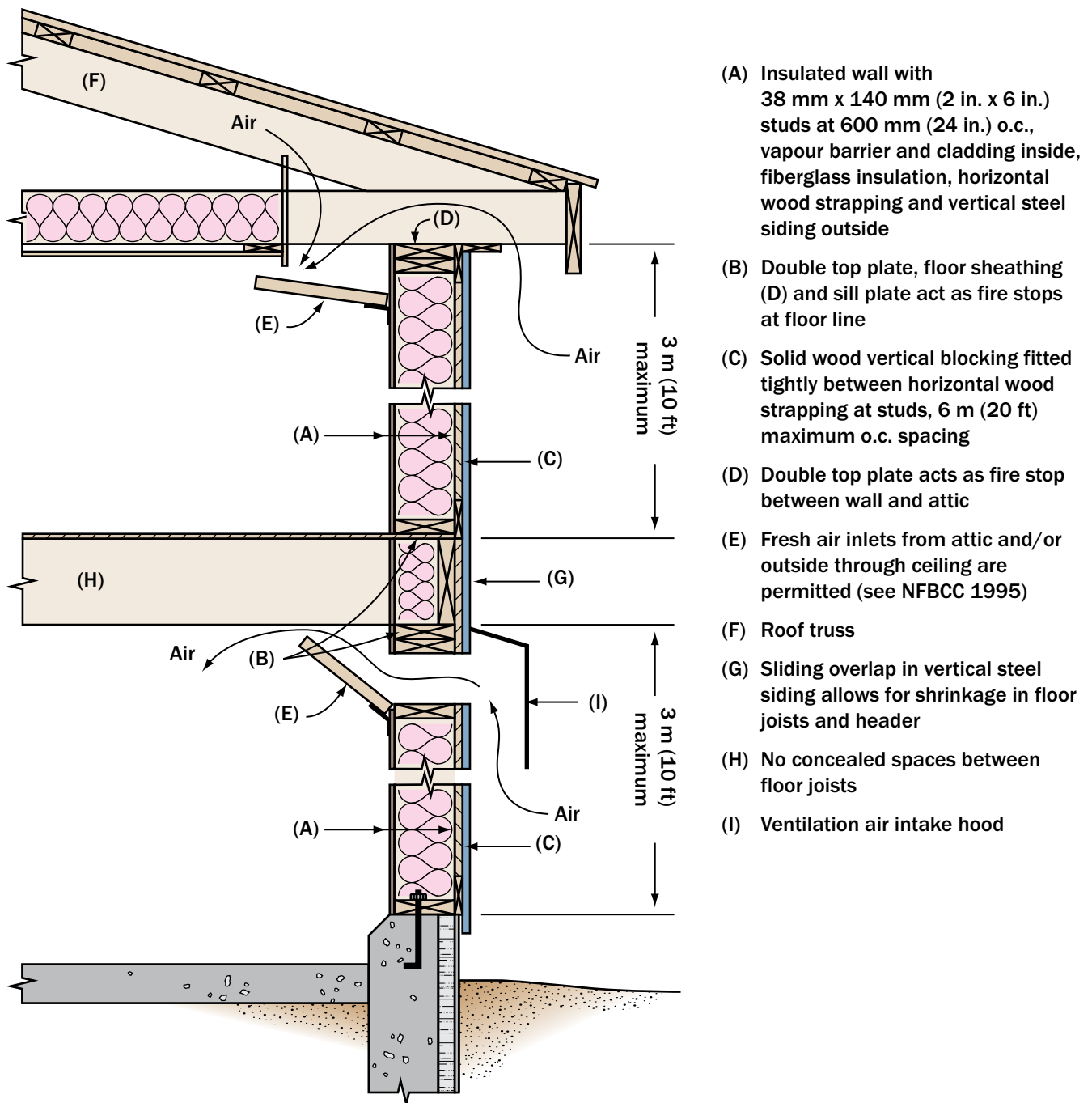

Figure 3.5. A two storey barn cross-section showing fire stopping locations.

Attic fire stops limit fire from moving quickly through the attic space of a building. The NFBCC requires fire stops in attic spaces be constructed at intervals no greater than 30 m (100 ft) in either direction. Construct fire stops to ensure there are no openings to allow fire to move quickly to the next space. Fire stops are commonly constructed using the following sheathing materials:

- cement board
- 0.38 mm (28 U.S. gauge) sheet steel
- 12.7 mm (½ in.) gypsum board
- 12.5 mm (½ in.) plywood, Oriented Strand Board (OSB) or wafer board with joints backed with similar material

The sheathing materials are often mounted on one side of the roof trusses in the attic space (Figure 3.6). The truss manufacturer can provide specific guidance if required. In all cases, the joints must be backed with similar material and sealed to create a draft-tight barrier to restrict the passage of smoke and flame.



Figure 3.6. Example of an attic fire stop under construction in a new calf barn.

Attic fire stops are one of the most neglected construction details in farm buildings. Pay particular attention to the tightness of the construction since it provides the critical function of reducing the rate of fire spread. If the fire stop is pierced with wiring, plumbing or ductwork, the space between the stopping material and the object piercing must be sealed and caulked with fire-rated material. A fire stop is expected to slow the progress of a fire by at least 15 minutes.

Unfortunately, the lack of proper attic fire stops, or breached fire stops in the attic, has contributed to the rapid progression of fires in several Ontario swine barns. Figure 3.7 shows a fire stop that has been breached by an opening, and would allow a fire to jump into the next attic compartment without slowing down.



Figure 3.7. This attic fire stop has an opening cut into it (arrow), removing its effectiveness in containing a fire.

(Photo credit: Randy Drysdale, Farm Mutual Reinsurance Plan)

Protection or closure of openings in fire separations

Ontario's Building Code and the NFBCC requires any permanent opening through a fire separation, like a doorway, window, etc., be equipped with a closure device. Closure means a device or assembly for closing an opening – a door, shutter, wired glass or glass block – and includes all components, such as hardware, closing devices, frames and anchors.

These closure devices close automatically during a fire to seal the opening (e.g. a metal roll-up door with a fusible link). Figure 3.8 shows a roll-up fire door controlled by a fusible link. When a higher temperature is encountered, as in a fire, the fusible link melts and the door closes to protect the adjoining compartment. Inspect all fusible links annually to identify signs of premature deterioration. Ensure this inspection is completed by a qualified individual.



Figure 3.8. This roll-up door protects an adjoining compartment by automatically closing in a fire.

(Photo credit: Cornell Iron Works Inc., Pennsylvania)

Ventilation openings in naturally ventilated farm buildings present a challenge for designers looking to maximize a building’s fire safety characteristics. These buildings have large openings in the sidewalls to allow the required air flow into the barn, providing a comfortable environment for livestock during warm weather conditions. During a fire, these large openings perform the same function, allowing large volumes of air to enter the building and provide oxygen to feed the fire. These unrestricted wall openings also present challenges where two buildings meet, providing a location for a fire to “jump” from one building to the other.

Proper location of fire separations in these buildings is critical to prevent fire spread. Construct the wall immediately adjacent to the fire separation as a solid wall without ventilation openings, to help stop a fire from jumping the fire separation. Another way to avoid this problem is to locate fire separations in hallways between buildings at a sufficient distance from other openings (Figures 3.9 and 3.10).

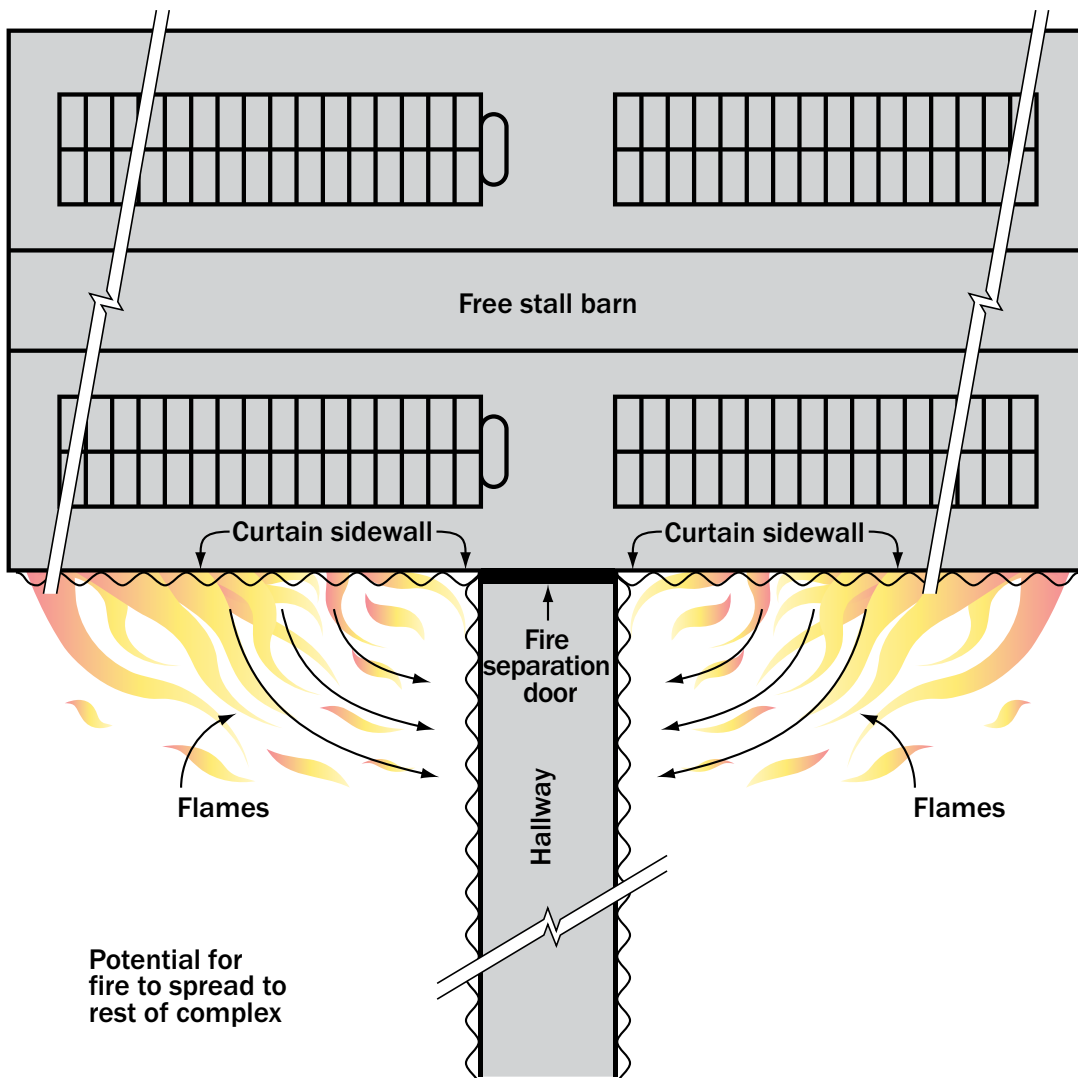

Figure 3.9. Unacceptable location of fire separation doors. This door location is unacceptable since a fire can easily jump past it.

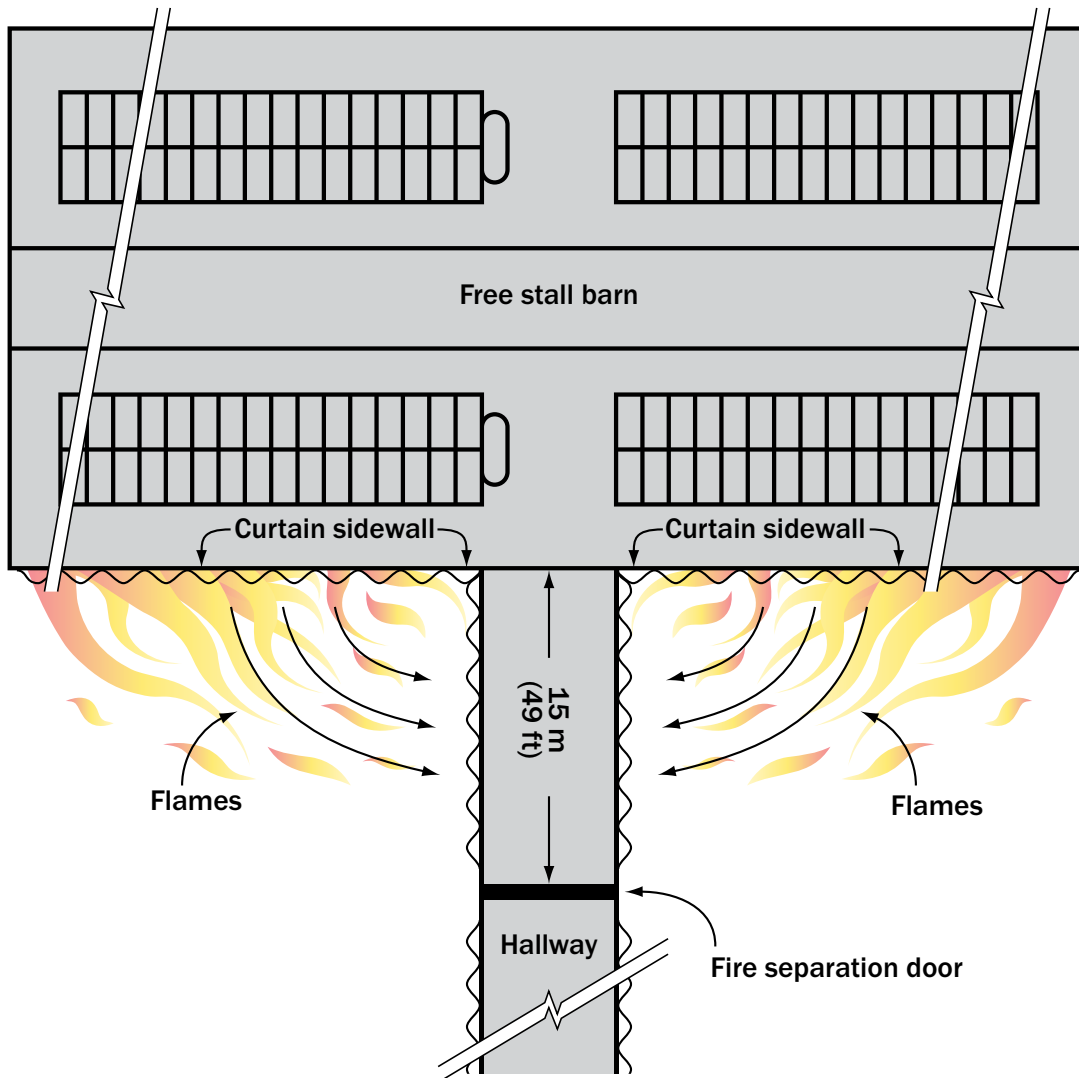

Figure 3.10. Acceptable location of fire separation doors. This door location is acceptable since a fire cannot easily jump past it.

Spatial Separation

Fire spreads by convection, conduction, radiation and/or direct flame contact. Spatial separation is a concept that reduces the chance of a fire spreading by radiation to adjacent buildings.

Radiation is the transfer of heat from flames and hot surfaces to solid objects that are in the direct path of the heat source. The hotter the source and the greater its ability to emit heat, the better the radiant heat transfer to objects in its path. On a smaller scale, radiation in everyday life is one way gas fireplaces transfer heat throughout houses.

Fire spreads by radiation to neighbouring buildings when nearby materials absorb enough heat and begin to smolder and then burn. Providing enough distance between all buildings helps minimize heat gain between the source of the fire and the surfaces of adjacent buildings. This distance gives firefighters the opportunity to apply water to the nearby building surfaces in an effort to reduce the temperature of each surface.

To reduce fire losses, and as a best management practice, TACFF recommends increased attention to fire stopping.

It is more efficient and practical to incorporate the recommended spatial separations for farm buildings at the design and siting stage, before construction begins (Table 3.3).

Table 3.3. TACFF Recommended Spatial Separation for Farm Buildings (according to their fire risk factor)

High Risk	Buildings containing flammable materials such as fuel storage <ul style="list-style-type: none"> Separate this room or building from other farm buildings by a minimum of 45 m (148 ft) or by using a fire separation with a minimum rating of 2 hours (i.e. providing exterior walls).
Low Risk	Poultry, swine and dairy barns, other livestock and non-livestock buildings, pesticide storages, hay, straw and feed storage areas, machinery storage buildings without fuel storage <ul style="list-style-type: none"> Separate these areas from other farm buildings by a minimum of 30 m (100 ft) or by using a fire separation with a minimum rating of 1 hour (i.e. providing exterior walls).
Special Areas	<ul style="list-style-type: none"> Electrical/mechanical rooms – separate from the remainder of the building using a fire separation with a minimum rating of 1 hour. All offices, staff rooms, washrooms and hallways that lead to exits should be lined with materials having a low flame spread index rating and low smoke developed classification. Protect these areas using smoke detectors/alarms and a direct exterior exit. A farm building of low human occupancy must not contain a residential occupancy. If this is the case, relocate the residential area to an independent building designed for this use.

Flame Spread

It is important to understand how fire spreads.

Compartments contain fire within a certain area, but designers also strive to reduce the rate at which flames and smoke spread within each compartment. Slowing down the development of a fire within a compartment provides more time for people to escape, and

increases the chance that the fire is manageable when the fire department arrives. Selection of interior sheathing materials significantly impact the rate fire spreads within each compartment.

As a best management practice, TACFF recommends that new buildings are set back from lot lines a minimum of 30 m (100 ft) to protect buildings on neighbouring properties.

Material choice

The availability of new materials for barn construction provides designers, builders and operators with more cladding options than ever before. Choose interior finish materials with low flame spread ratings that do not support combustion, for example, concrete or tile surfaces and to a lesser extent steel sheathing. When steel is subjected to high heat, it buckles and air gaps may open at the sheet overlap joints, allowing the fire to penetrate into the wall or ceiling cavity. Noxious gases and smoke are given off by most building materials in varying quantities. While many plastic and vinyl materials show low flame/spread ratings, they melt very quickly when ignited. If used on the walls and ceiling without any backing materials like drywall, the melted product leaves openings where fire can spread quickly into wall and attic spaces (Figure 3.11).



Figure 3.11. Melted vinyl sheathing on ceiling. Note the lack of backing behind the vinyl leaving the attic space exposed.

(Photo credit: R. Drysdale, Farm Mutual Reinsurance Plan)

Specific sheathing materials contribute to the spread of flames at varying rates. Materials give off varying amounts of smoke as they burn. Table 3.4 provides a guide to the characteristics of some common interior sheathing materials.

Table 3.4. Flame Spread Rating and Smoke Developed Classification of Common Building Material Systems

Type of Construction	Flame Spread Rating (FSR) ¹	Smoke Developed Classification (SDC) ²	Comment
Concrete sandwich wall, concrete block	-	-	Does not support combustion
Walls – insulated stud or post-frame wall construction with the following materials applied to the interior surface:			
Curtain sidewall	High	High	Some proprietary products are treated to reduce the FSR and SDC – check with manufacturer.
Vinyl sheathing	Low	High	Some proprietary products are treated to reduce the FSR and SDC – check with manufacturer.
Fiberglass over plywood	Low	Low	Some proprietary products are treated to reduce the FSR and SDC – check with manufacturer.
Polyethylene board (puckboard)	Low	High	Some proprietary products are treated to reduce the FSR and SDC – check with manufacturer.

Ceilings – typically roof trusses @ 1,200 mm (48 in.) centres, insulated with fiberglass (or equivalent) insulation materials, and with the following materials applied to the interior surface:			
Vinyl	Low	High	Some proprietary products are treated to reduce the FSR and SDC – check with manufacturer.
Corrugated PVC	Low	High	Some proprietary products are treated to reduce the FSR and SDC – check with manufacturer.
Corrugated fiberglass	Low	Low	Some proprietary products are treated to reduce the FSR and SDC – check with manufacturer.
Painted/galvanized metal	-	-	Does not support combustion – see NOTE below
Painted plywood	High	High	Some proprietary products are treated to reduce the FSR and SDC – check with manufacturer.
Woven polyethylene	High	High	Some proprietary products are treated to reduce the FSR and SDC – check with manufacturer.

¹FSR values relate to a classification system for various substrates that indicate how far flames will spread in a given amount of time.

²SDC values are related to the smoke concentrations given off from burning materials.

Note: The NFBCC requires that foamed plastic insulation materials are protected or covered. There must be no foamed plastic exposed to the spaces occupied by people and livestock as many foamed plastic insulations can be accidentally ignited by sparks and other ignition sources. Once these foams are ignited, people and livestock are at risk because the foams quickly produce flames and toxic smoke. Two suitable covering materials are exterior-grade plywood and galvanized sheet steel since they have acceptable levels of fire protection, durability and moisture resistance.

Plastics create very noxious gases when burned. At very high temperatures, the gases that develop may suddenly cause flashover of the entire room and increase the rate of fire spread.

Installation of drywall in a high moisture area, like a livestock barn, is not recommended due to the high humidity levels in the housing area. Where drywall is used, provide a vapour barrier in an appropriate location that protects the drywall from the high moisture environment.

Drywall can be used in dry environment areas of the barn that do not house livestock. For example, use two layers of fire-rated drywall to line the interior of the mechanical electrical room to provide a fire separation. A fire that starts in this area will take longer to spread to the rest of the building, providing more time for evacuation and extinguishing.

For harsh environments (humid and corrosive), choose durable sheathing materials that often have a higher fire-resistance rating (i.e. concrete board, sandwich wall construction, fiberglass-coated plywood).

Electrical Code Considerations

There are nine key recommendations to reduce the effects of the corrosive atmosphere in the livestock or poultry housing area of the building.

1. Use copper wiring for all conductor and cable assemblies.
2. Use suitable wiring methods in livestock or poultry housing areas for all locations. Provide adequate ventilation in the housing area. Most animal confinement areas are humid at times, or wet from cleaning practices that regularly wash down areas with high pressure washing systems.
3. Install only electrical equipment that is essential to the operation in the livestock or poultry housing area. Install equipment containing fuses or breakers only in locations suitably separated from the confinement area and which are supplied with clean, dry, temperature controlled air (e.g. offices, electrical/mechanical rooms, etc.).
4. Hard wire essential equipment and lighting in the livestock area, where practical, using wire connectors with an anti-corrosion agent. This eliminates the need for some of the receptacles, reducing possible failure points in the electrical system.
5. Where it is essential to use portable lighting or equipment fed from receptacles, use approved flexible cords, cord caps and receptacles for the location. Figure 3.12 shows examples of wet-rated cord caps.



Figure 3.12. Wet-rated cord caps. Cap is a term the electrical industry uses to describe either male or female cord ends or plugs.

(Photo credit: Electrical Safety Authority)



Figure 3.13. The heat lamp is connected directly to a wet-rated electrical box and includes a wet-rated cord cap connection so the lamp fixture can be removed. When the lamp is removed, the cover is placed on the female cap end to protect it from corrosion.

6. As an alternative to using a receptacle, remove the cord cap and hard wire the equipment's flexible cord to the branch circuit with the use of a box connector approved for the location (Figure 3.13). This is the recommended practice to eliminate points of failure and reduce installation costs.
7. Do not use extension cords as permanent wiring.
8. Ontario Electrical Safety Code requires the protection of electrical wiring from rodents in walls and attics.
9. Areas in barns and farm operations that use special processes, such as grain handling or grinding, must meet additional conditions. The Code specifies equipment used in these environments to meet dust and explosion requirements.

Heating System Considerations

The TSSA Fuels Safety Program administers the fuel-related safety services associated with the safe transportation, storage, handling and use of hydrocarbon fuels (i.e. gasoline, diesel, propane and natural gas in Ontario).

- Ensure any suspended non-vented box heaters in a barn are able to withstand a wet and corrosive environment. Connect the heater to the ceiling with four jack chains that all have separate termination points (Figure 3.14).



Figure 3.14. A box heater properly suspended on four jack chains.
Note that a faulty gas valve resulted in charring of the electrical conduit.
(Photo credit: R. Drysdale, Farm Mutual Reinsurance Plan)

- Adhere to the clearance requirements for the heater. Each heater has these requirements clearly posted on the unit.
- Use bright yellow to paint natural gas or propane lines that pass through the building, to avoid accidental damage and protect the piping.
- Install bollards to protect exposed natural gas valves near the building from vehicle impact.
- Align the ends of on-farm propane tanks parallel to the farm building, at least 3 m (10 ft) from the building. If the tank is close to a driveway or parking lot, install vehicle protection (bollards).
- The NFBCC requires all fuel-fired appliances be located in a dedicated room, separated from the remainder of the building with a minimum 30 minute fire separation.

As a best management practice, TACFF recommends constructing a one hour fire separation wall between the dedicated room housing the fuel-fired appliance from the rest of the building.



4.0 Reducing the Impact of Fire

Best management practices for fire safety are recommended to go beyond the requirements of applicable Codes and regulations. The measures in this section are not necessarily required by applicable Codes but are recommended for consideration because they are effective. They are precautions that can minimize the damage from fire or describe actions to take in the event of a fire.

Detection and Suppression Systems

Fire alarm systems

Automatic fire detection connected to a fire alarm system provides very effective, early notification of fire. If notification is not received almost immediately, a fire can be out of control before personnel have time to take action or evacuate the building. A combination of flashing lights in visible locations and alarms that can be heard both inside and outside of the building are most effective. Consider the corrosive environment inside most livestock buildings in the design and installation. Ongoing testing and maintenance is essential to ensure the system continues to operate properly.

Fire extinguishers

Knowing how to correctly use a fire extinguisher can stop a small fire from growing into a large one. It is a best practice to install fire extinguishers in every building. Select the extinguisher based on the hazards that are present, and any special environmental conditions in the building. General purpose fire extinguishers are a good choice for overall protection. Use recognized standards and advice from industry experts to select and place fire extinguishers for maximum benefit. Remember to locate fire extinguishers to be highly visible and easily reached. Passageways and aisles that lead to exits are good locations (Figure 4.1). Do not block exit paths with fire extinguishers or place where they are subject to mechanical damage from moving objects. Inspect extinguishers monthly for good working condition and service annually by qualified personnel.

Train all employees in the use of fire extinguishers. Ensure training covers extinguisher locations, different classes of fires, and when and how to use extinguishers. Most importantly, train employees to never place their lives at risk to fight a fire.



Figure 4.1. A fire extinguisher located next to an exit.

Sprinkler systems

Designed and installed correctly, sprinkler systems distribute water on the source of the fire. Although many farm buildings have challenging conditions such as cold winter temperatures, dust, corrosive environments, aggressive cleaning routines and limited water supply, these problems are overcome with a unique design and appropriate maintenance protocols. For example, a dry-pipe system using corrosion resistant components can have a serviceable life in cold and corrosive locations. With a dry-pipe system, water is not present in the pipes until a fire, when a valve opens to charge the system with water. There are other types of systems and unique operating features to consider. Operators are advised to consult with experts to determine if a sprinkler system is the right choice for their particular operation.

Fire Department Access

In the event of a fire, fire personnel must be able to access the site with their equipment in order to contain and/or extinguish the fire as quickly as possible (Figure 4.2).



Figure 4.2. This swine facility was devastated by a fire. Note the lack of an access road completely around the buildings which hampered the ability to fight the fire.

(Photo credit: P. Stolk, Farm Mutual Reinsurance Plan)

A firefighting unit may require access to several sides of a building. Proper access roads around farm buildings provide the fire department with a better opportunity to fight a fire. Table 4.1 lists recommendations for laneway access to farm buildings of varying sizes. Building complex area is the total footprint area of all buildings on the property that are interconnected by hallways/passageways.

Table 4.1. Recommended Access Road Configurations

Overall Building Complex Area		Type of Road Access Needed
(m ²)	(ft ²)	
1,200	12,900	One side
2,400	25,800	Two sides
3,600	38,700	Three sides
4,800 +	51,600	All sides

There are several additional factors to consider when constructing a laneway.

- Place the laneway a minimum of 15 m (50 ft) away from the building.
- The minimum width of the laneway is 3.7 m (12 ft) for the entire length of the lane, and greater than this at the entrance and at points where the laneway direction changes. Allow for vehicles with a large turning radius.
- Construct the laneway wide enough for two vehicles to pass, at least in several places.
- Set fences back, at least 2.4 m (8 ft), along the side of the laneway to allow for adequate snow removal. Keep all overhead objects, including branches and wires, cleared to a height of 6 m (20 ft) from the surface of the yard or laneway.
- Clearly identify all four corners of laneway bridges, culverts and Texas gates where the laneway meets the bridge. When a new bridge or culvert is necessary, construct it of corrugated steel and/or concrete. Consult a professional engineer to evaluate an existing bridge or culvert or to design a new crossing.
- Create a laneway wide enough at the road to allow longer vehicles to turn without extending past the edge of the laneway.

The fire department access laneways need all-season maintenance. Keep the snow cleared during winter months. Do not leave machinery or vehicles parked where they restrict access along the laneway or to an available water supply.

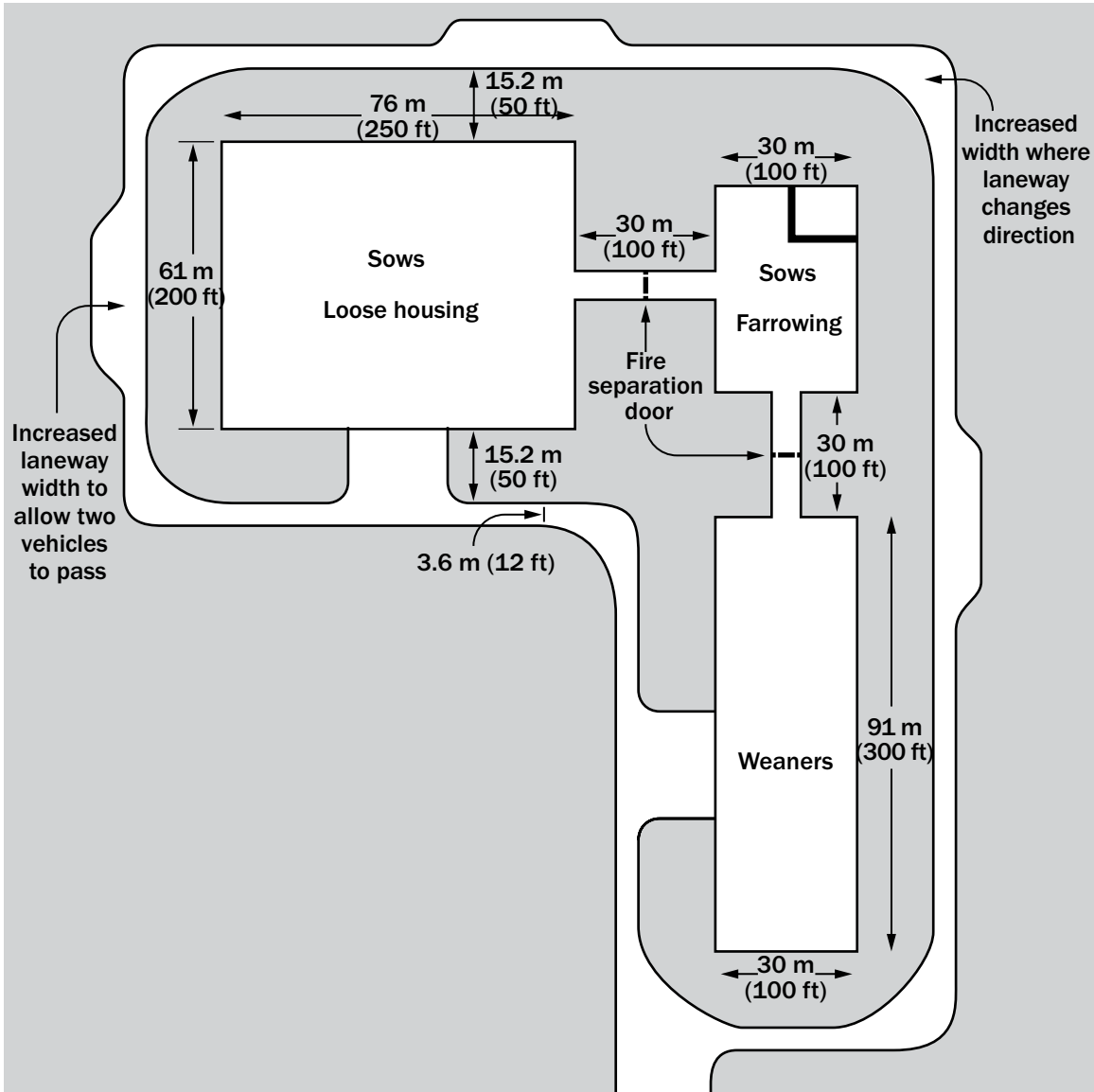

Figure 4.3. A swine complex that exceeds 4,800 m² (51,600 ft²). Access roads are recommended on all sides of the operation. All-season roadways that can handle equipment and truck traffic are effective use of this space.

Water Supply for Fire Fighting

Water for fire fighting can come from a variety of sources. Farm ponds, concrete tanks, public water supplies/hydrants are common sources. Firefighting units can also transport limited water quantities to the site.

The required volume of water for fighting a fire depends on several factors, including:

- type of construction (combustible vs. non-combustible)
- proximity to other buildings
- fire protection features (i.e. automatic sprinklers)

It is difficult to provide a guide on water capacity, however more water is always a positive asset. The local fire department may be able to provide recommendations on emergency water supply and appropriate connections.

For ponds and concrete tanks, install a standard, remote water connection (dry hydrant) adjacent to the water storage for direct connection by the local fire department. A dry hydrant is useful, but not always required for obtaining water from a pond. Many rural fire departments have floating pumps and screened supply lines for this purpose. If a nearby pond is the source of supply water for fire suppression, discuss the options with the fire department so their capabilities are understood ahead of time. Figure 4.4 shows a simple design for a dry hydrant water connection for a farm pond. Figures 4.5 and 4.6 show two views of a dry hydrant installation.

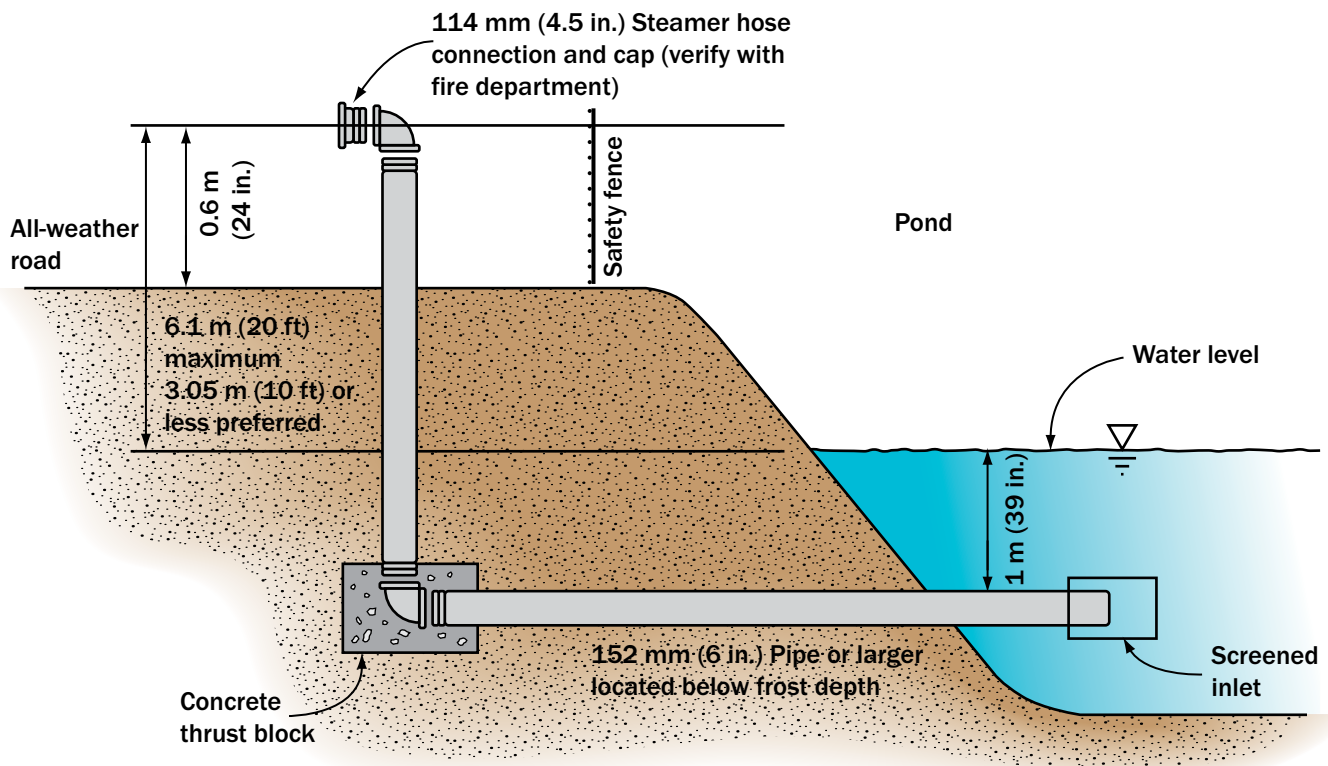

Figure 4.4. A simple dry hydrant attachment point used to allow fire departments to draw water from a farm pond in an emergency situation.



Figure 4.5. Dry hydrant showing all features.



Figure 4.6. Dry hydrant standpipe connection.

Evacuation

In the event of a fire, people must be able to exit the building quickly and safely to prevent the loss of human life. The size, number and location of these exits are outlined in the NFBCC.

The NFBCC requires that exits are visible and clearly marked. A best management practice recommends the use of signage and lighting to help people locate these exits during a fire.

Number of fire exits

The NFBCC specifies that every farm building have at least two fire exits, at opposite ends of the building. There is an exception in the NFBCC for buildings of low human occupancy having less than 200 m² (2,150 ft²) of floor area and used to store bulk crops of low combustibility. These buildings may be served by one fire exit.

Travel distance

The NFBCC requires the travel distance to an exit in a farm building of low human occupancy not exceed 20 m (66 ft) in buildings where more than 100 L of liquid fuel is stored, or 45 m (148 ft) in all other farm buildings or the exits are placed around the perimeter of the building and are not more than 60 m (197 ft) apart, measured along the perimeter.

Figure 4.7 and Figure 4.8 show exit locations in a single and two storey farm building.

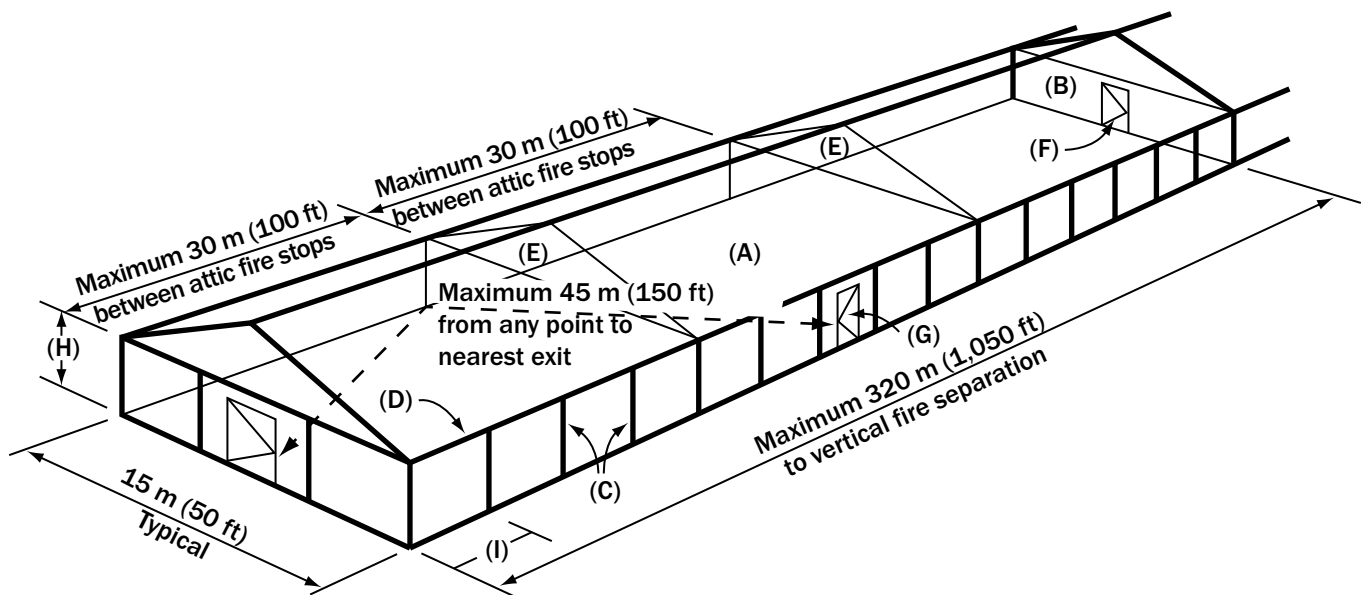

Figure 4.7. The requirements for fire safety in a single storey farm building.

Notes:

- (A) Maximum floor area per *fire compartment* is 4,800 m² (51,600 ft²).
- (B) 1 hour *fire separation* if floor area exceeds 4,800 m² (51,600 ft²).
- (C) *Vertical fire stops* in walls (Figure 3.5).
- (D) *Horizontal fire stops* between walls and attic.
- (E) *Attic fire stops* (Article 3.1.3.4 of the NFBCC 1995).
- (F) Exit doors at opposite ends of area.
- (G) Additional exits in sidewall, not over 45 m (147 ft, 8 in.) from any point (also used as emergency ventilation if electric power fails).
- (H) The maximum vertical dimension of any concealed space in a wall or partition of *combustible construction* cannot exceed 3 m (10 ft).
- (I) The maximum horizontal dimension of any concealed space in a wall or partition of *combustible construction* cannot exceed 6 m (20 ft).

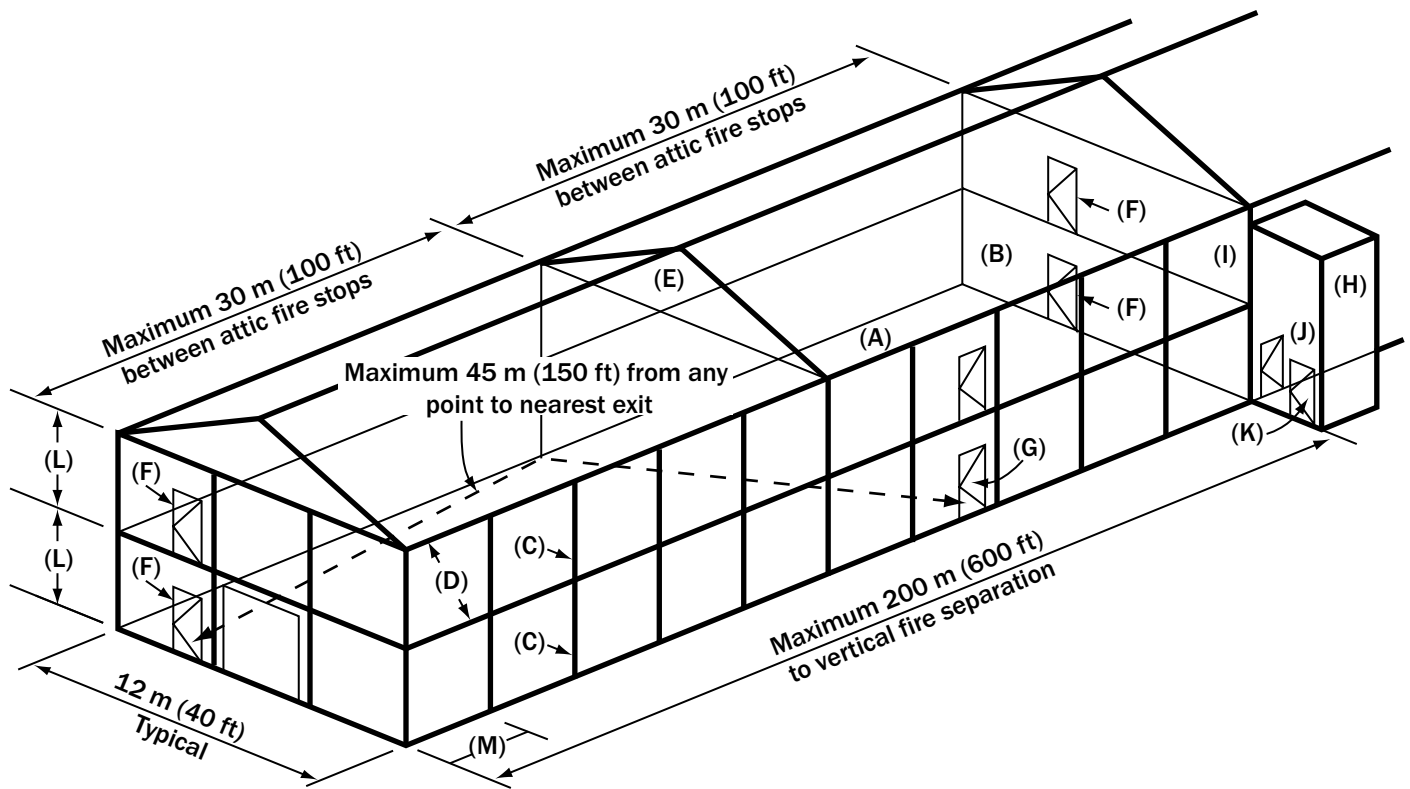

Figure 4.8. Fire safety and egress requirements for a two storey farm building with an attached furnace room.

Notes:

- (A) Maximum floor area per fire compartment is 2,400 m² (25,800 ft²).
- (B) 1 hour fire separation if floor area of each fire compartment exceeds 2,400 m² (25,800 ft²).
- (C) Vertical fire stops in walls (Figure 3.5).
- (D) Horizontal fire stops between storeys and between walls and attic (Figure 3.5).
- (E) Attic fire stops (Article 3.1.3.4. of the NFBCC 1995).
- (F) Exit doors at opposite ends of floor area; provide ladders from upper storeys.
- (G) Additional exits in sidewall, not over 45 m (147 ft, 8 in.) from any point (also used as emergency ventilation and for loading poultry, if applicable).
- (H) Attached furnace room with on exit (under 200 m² or 2,150 ft² floor area).
- (I) Required fire separation of 30 minutes.
- (J) Door through fire separation must have a fire-protection rating of at least 20 minutes.
- (K) Outside access door eliminates the need for an expensive door.
- (L) The maximum vertical dimension of any concealed space in a wall or partition of combustible construction cannot exceed 3 m (10 ft).
- (M) The maximum horizontal dimension of any concealed space in a wall or partition of combustible construction cannot exceed 6 m (20 ft).

Exit type

The NFBCC specifies that fire exits in farm buildings consist of an exterior doorway or an opening window or panel that provides an opening measuring not less than 550 mm x 900 mm (21.5 in. x 35 in.).

2nd floor access ladder

The NFBCC requires a permanently installed exterior ladder for all fire exit openings located more than 2.5 m (8.2 ft) above ground level. Figure 4.9 shows a ladder attached to the outside of a two storey poultry building. Ensure ladders/platforms comply with all safety requirements.



Figure 4.9. An example of a fire exit ladder located beside exit doors on a two storey broiler barn.

Fire exit signage

Post permanent signs beside all fire exits in the building/compartment. Rooms connecting into common hallways should post signs in the hallway in front of the doorway, indicating the direction to an exit. If using electrical signs, ensure these signs have a battery backup system to remain lit in the event of a power outage. Figure 4.10 shows a properly marked exit.



Figure 4.10. An exit at the end of this alleyway is clearly identified.

Alternative exits (removable panels/windows)

Clearly mark these panels and test them periodically to ensure they are operational. The panels must open without the use of tools. Attach handles for ease of manipulating the panels. Inform staff using the facility that these are available as emergency exits.

Mechanical/electrical room exit

These rooms should have a direct exit to the outside. When a direct exit to the outside is not possible, consider a pass-through exit (through another room). In these cases, ensure employees determine the fire location before entering the room, in order to get to the exit.

Obstructions

Make every effort to keep exit paths and exit doors clear of obstructions from equipment, machinery, feed and similar items. A daily walk through the building will ensure exits and exit paths are unobstructed.

Low level lighting

Install a battery backup system in hallways and areas where a power outage could cause the area to become dark, to provide a minimum lighting level to allow safe exit.

Door swing/door locks/pins

Mount self locking doors along the vertical axis and ensure they open outwards, as a best management practice. Keep the area outside of the door clear of snow and debris to ensure the door is operational.

Training guide

Best management practices recommend that a farm operator provide training to all employees on the location of fire exits and extinguishers, and where to go in the event of a fire. Instruct employees on procedures for using the extinguishers and contacting the fire department after leaving the building. Post signage with the fire department's phone number, directions to the property and the 911 address at each telephone on the farm property. The caller is only expected to read supplied paperwork because the stress of the situation may cause them to forget critical information.

5.0 Assessing Your Risk

Self Assessment of a Farm Building

Many barn fires are preventable. Use the checklist to identify fire risk in farm buildings.

Category		Yes	No
Structure			
1.	The largest, separate fire compartment size is less than 4,800 m ² (51672 ft ²)?		
2.	Buildings are located at least 30 m (100 ft) from each other or have properly constructed (1 hour) fire rated walls separating the individual fire compartments?		
3.	Properly constructed fire stops exist in the attic at 30 m (100 ft) intervals?		
4.	No unsealed gaps or passageways in attic fire stops?		
5.	Interior sheathing materials have low Flame Spread Ratings and Smoke Developed Classifications as outlined in Table 3.4?		
Electrical System			
6.	Electrical inspection completed within the past year?		
7.	Thermographic inspection of the entire electrical system, completed during the period when the barn is at its peak electrical demand, completed within the past year?		
8.	Any wiring passing through concealed spaces is enclosed in conduit?		
9.	All electrical connections are hard wired (no extension cords)?		
10.	An electrical/mechanical room contains components, including the main electrical panel, and is separated from the livestock air space with properly constructed fire rated walls (1 hour minimum)?		
11.	All electrical equipment used in the barn displays a Canadian electrical approval stamp (e.g. CSA, ULC)?		
Heating System			
12.	Open flame box heaters or radiant tube heaters (that draw combustion air or exhaust directly into the barn space) are not used in a barn where methane gas can accumulate in significant concentrations?		
13.	Sufficient space exists between all heating appliances and combustible building features (minimum clearance requirements maintained)?		
14.	Heat shields for all heaters are in place (if required)?		
15.	Maintenance checks of all heating devices have been completed as per the manufacturer's recommendations (minimum once per year)?		
16.	Bollards are used to protect propane and liquid fuel tanks and gas valves from vehicle impact?		
Stored Products			
17.	Less than a two day supply of hay, straw, sawdust, feed or similar products are stored within barn?		
18.	Separate buildings are used to store larger quantities of hay, straw, sawdust, feed or similar products. Buildings are separated by a minimum distance of 30 m (100 ft) or by using a fire separation with a minimum rating of 1 hour (i.e. providing exterior walls)?		
19.	Clutter and combustible products are removed from the barn on a regular basis?		
20.	Flammables (diesel, gas, propane) are stored in approved containers that are regularly inspected (minimum once per year)?		
Laneway and Water Supply (verify these items with local fire department)			
21.	An all-weather laneway provides adequate fire truck access to the required sides of the building?		
22.	Roadway is regularly maintained (snow removed, adequately graded)?		
23.	Adequate, year-round accessible water is available on-farm for fighting fires?		
24.	A standard remote connector (hydrant) is installed adjacent to the water supply for direct connection by the local fire department?		
Safety, Exit and Lighting			
25.	Sufficient number of exits is available to allow safe exit from all storeys and rooms?		
26.	Emergency lighting and signage is available to mark the location of all exits?		
27.	Proper ladders and stairs are used for exterior exit from upper storeys?		
28.	Fire extinguishers are in place and all employees are trained for proper use?		
29.	A clear path of travel to and through all exits is in place?		

Summary

Everyone associated with the design and operation of a farm building should have fire safety in mind. Farm operators need to consider the safety of their family, workers and animals. Extensive financial loss and business interruption are critical reasons to follow fire safety best practices. These practices include the consistent application of existing regulatory requirements, and best management practices that further reduce risk. Ensure the farm is properly insured to reduce the impact of fire.

Farm buildings present a unique fire risk situation. For example, some farms are very large or have wet, corrosive environments where normal electrical installations are not safe enough. There are cost effective ways to improve the fire safety characteristics of a building, particularly at the design stage. Many of the leading causes of barn fires have been identified and the farming community needs to take action to address these causes.

Many fire safety precautions and procedures are in place to limit the severity and effects of fire. Separating high risk areas from the rest of the building, properly constructing and maintaining fire stops, and implementing a training program are some of the ways to reduce the impact of fire on the farm.

With attention to detail, fire safety risks to farm workers, emergency responders and animals can be reduced, and the trend of increasing financial losses reversed.

For additional information

National Farm Building Code of Canada 1995 – www.nrc-cnrc.gc.ca

Building Code Act, 1992 – www.e-laws.gov.on.ca

Building Code 2006 (Ontario Regulation 350/06) under the *Building Code Act, 1992* – www.e-laws.gov.on.ca

Building Code 1997 (Ontario Regulation 403/97) under the *Building Code Act, 1992* – www.e-laws.gov.on.ca

Construction Guide for Farm Buildings, 2003 – www.orderline.com

Electrical Safety Authority – www.esasafe.com/GeneralPublic/index.php

Technical Standards and Safety Authority – www.tssa.org





www.ontario.ca

