

Oil, Gas and Salt Resources of Ontario, Provincial Operating Standards

Version 3.0

Effective July 1, 2023

Oil, Gas and Salt Resources of Ontario, Provincial Operating Standards

ISBN 978-1-4868-6007-4 (HTML)

ISBN 978-1-4868-6008-1 (PDF)

© King's Printer for Ontario, 2022

Preface

The technical standards presented in the following cover wells and works regulated under the Oil, Gas and Salt Resources Act, R.S.O. 1990 c.P.12 as amended and regulations thereunder. These standards are the minimum requirements for the design, installation, operation, abandonment and safety of wells and works. These standards are not intended for use as a design handbook. The exercise of competent engineering judgement and application of practical experience are necessary requirements for use concurrently with these standards.

The requirements of these standards are adequate under conditions normally encountered in oil, gas and salt resource industry activities involving wells and works. Requirements for abnormal or unusual conditions are not specifically provided for, nor are details of engineering or construction prescribed. It is intended that all work performed within the scope of these standards shall meet or exceed the safety standards expressed or implied herein. As with all new standards, it is expected that changes may have to be made from time to time based on new experience or technology, or both.

The following publications are referenced within this standard. Where such a reference is made, it shall be read as a reference to the most current edition of the publication in effect, including all published amendments.

API Recommended Practice 651, Cathodic Protection of Aboveground Petroleum Storage Tanks (API RP 651)

API Specification 6A, Specification for Wellhead and Tree Equipment (API Spec 6A)

ASME B31.1, Power Piping (ASME B31.1)

API Bulletin 5C4, Bulletin on Round Thread Casing Joint Strength with Combined Internal Pressure and Bending (API 5C4)

API Recommended Practice 500, Recommended Practice for Classification of Locations for Electrical Installations at Petroleum Facilities Classified as Class I, Division I and Division 2 (API RP 500)

API Recommended Practice 5A5, Field Inspection of New Casing, Tubing, and Plain-end Drill Pipe (API RP 5A5)

API Recommended Practice 5C1, Recommended Practice for Care and Use of Casing and Tubing (API RP 5C1)

API Specification 10A, Specification for Cements and Materials for Well Cementing (API Spec 10A)

API Specification 12B, Specification for Bolted Tanks for Storage of Production Liquids (API Spec 12B)

API Specification 12D, Specification for Field Welded Tanks for Storage of Production Liquids (API Spec 12D)

API Specification 12F, Specification for Shop Welded Tanks for Storage of Production Liquids (API Spec 12F)

API Specification 12P, Specification for Fiberglass Reinforced Plastic Tanks (API Spec 12P)

API Specification 5CT, Specification for Casing and Tubing (API Spec 5CT)

API Standard 12R1 Installation, Operation, Maintenance, Inspection, and Repair of Tanks in Production Service (API Std 12R1)

API Standard 521, Pressure-relieving and Depressuring Systems (API Std 521)

API Standard 650, Welded Tanks for Oil Storage (API Std 650)

API Standard 653, Tank Inspection, Repair, Alteration, and Reconstruction (API Std 653)

API Technical Report 5C3, Calculating Performance Properties of Pipe Used as Casing or Tubing (API TR 5C3)

CSA B51, Boiler, Pressure Vessel, and Pressure Piping Code (CSA B51)

CSA Z341 SERIES, Storage of Hydrocarbons in Underground Formations (CSA Z341)

CSA Z662, Oil and Gas Pipeline Systems (CSA Z662)

Transport Canada TP 127 E, Ships Electrical Standards (TP 127 E)

Ontario Electrical Safety Code, as adopted by Ontario Regulation 164/99 under the Electricity Act, 1998 (Ontario Electrical Code)

Building Code, under Ontario Regulation 332/12 under the Building Code Act, 1992 (Building Code)

Table of Contents

Preface	i
Part 1. Well Licence Application	1
Part 2. Injection Permits	6
Part 3. Well Drilling	9
Part 4. Blowout Prevention (BOP)	32
Part 5. Works.....	52
Part 6. Production	64
Part 7. Oil Field Fluid Disposal Wells.....	70
Part 8. Well Servicing	78
Part 9. Solution Mining.....	80
Part 10. Hydrocarbon Storage.....	86
Part 11. Well Plugging.....	87
Part 12. Oil, Gas and Salt Resources Trust.....	92
Part 13. Reporting	94
Part 14. Historical Oil Field Standards.....	102
Part 15. Glossary	105
SCHEDULE 1 – Drilling BOP Requirements.....	110
SCHEDULE 2 – Well Servicing BOP Requirements.....	116
Figures 1-4.....	120

Part 1. Well Licence Application

Applications for well licences shall be made in duplicate on Form 1. Exact reproductions of Form 1 are acceptable.

1.1. Application Form 1

Applicants shall complete Form 1 in the following manner:

- (a) all sections of the form shall be completed including the name of the drilling contractor (if known at the time of application) except for sections labelled for Ministry use; and
- (b) all numerical data shall be submitted in the International System of Units (SI).

1.2. Incomplete Applications

Incomplete applications will not be processed until missing information is provided. Missing information may be submitted:

- (a) by fax to the Petroleum **Operations Section**, Ministry of Natural Resources and **Forestry** at (519) 873-4645; or
- (b) by editing electronically filed applications.

1.3. Application Exhibits

All applications must be accompanied by:

- (a) for wells located:
 - (i) on land, a well location plan that complies with **section 1.9**,
 - (ii) in water covered areas, a well location plan that complies with **section 1.9** that is submitted with Form 7;
- (b) a drilling program that provides further details on the following:
 - (i) a geological prognosis of formation tops and expected oil, gas, water and loss of circulation zones and pressures;
 - (ii) drilling rig type(s);
 - (iii) the hole size, casing size, grade, weight for the entire length of the well;

Oil, Gas and Salt Resources of Ontario, Provincial Operating Standards

- (iv) a well bore schematic diagram showing expected casing setting points, hole and casing size, how casing is set, water and hydrocarbon zones;
 - (v) contact personnel and phone numbers;
 - (vi) drilling procedures described in sequence;
 - (vii) casing and cementing procedures including cement type, additives, volumes and tops;
 - (viii) sample, coring, logging, testing and surveying programs;
 - (ix) casing and formation integrity testing procedures;
 - (x) drilling fluids;
 - (xi) proposed alternatives or contingencies to accomplish isolation of the required formations should the general program fail where specific ground or drilling conditions create problems e.g. lost circulation zones, aquifers, or other unusual conditions;
- (c) if the well is located in a unitized area, a map showing the unit area and unitized substances; and
- (d) the well licence application fee.

1.4. Application Fee

The application fee shall be in the form of a money order, cash, cheque or pre-authorized debit from an account or credit card, or credit or debit card payable to the Minister of Finance, and submitted with the well licence application.

1.5. Off-target Location

Where an operator wishes to drill a well in an off-target location, the operator shall present to the Ministry at the time of application the geological or topographic reasons that explain why it is unfeasible to drill the well within the target area.

1.6. Send To

Applications shall be submitted to Petroleum **Operations Section**, Ministry of Natural Resources **and Forestry**, 659 Exeter Road, London, Ontario N6E 1L3, **or by email to: posrecords@ontario.ca.**

Note: Prior to applying for a well licence the operator shall establish security for the proposed well in accordance with **Ontario Regulation 245/97** and provide information on such security on Form 1 "Application for a Well Licence".

1.7. Posting Well Licences

The operator shall post a copy of the well licence at the well site during all well drilling, workover or service operations involving a drilling or service rig.

1.8. Well Names

The operator shall:

- (a) limit the length of the well name to 30 characters including spaces;
- (b) always reference the well licence number and original well name in any correspondence with the Ministry regarding the well;
- (c) not change the name of the well without Ministry approval; and
- (d) in the case of problem or dispute over the well name, use the well name established by the Ministry

1.9. Well Location Plan

The operator shall submit a well location plan that meets or exceeds the quality shown in Figure 1 as part of the application for a well licence. The plan shall be a scaled drawing showing:

- (a) the exact surface coordinates of the well taken from two intersecting township lot boundaries where the North-South coordinates are to be determined first, and then the East-West coordinates taken perpendicular to the direction of the North-South measurement;
- (b) the angle between the directions used to determine North-South and East-West coordinates in subsection (a);
- (c) the ground elevation of the well site above mean sea level;
- (d) a clearly drawn North arrow;
- (e) the well name and location (onshore: geographic township, tract, lot and concession; offshore: lake, block and tract);

Oil, Gas and Salt Resources of Ontario, Provincial Operating Standards

- (f) all dwellings, agricultural, commercial or industrial buildings, schools, churches, places of public assembly, high voltage power lines, road allowances, transmission pipelines or other occupied utility right of ways, rivers, streams or shorelines, including labeling, that are located within 100 metres of the well site;
- (g) the well's location and the spacing unit required for the well with its target area and the location of the spacing unit within the township lot(s). (Note: Where a well's location is off-target, the plan shall indicate the spacing unit necessary for the well by combining the affected tracts, spacing units or unit areas as the case may be.);
- (h) the geographic coordinates (latitude and longitude) of the:
 - (i) surface location of the well, and
 - (ii) bottomhole location of the well for deviated, horizontal and lateral wells; and
- (i) the name of the person who prepared the plan and the date the plan was prepared.

1.9.1. Units, Reporting and Datum

Measurements used to prepare the well location plan shall:

- (a) be presented in the International System of Units (SI units);
- (b) use geographic coordinates (north latitude and west longitude) based on the North American Datum 83 (NAD 83) measured and reported to the nearest 100th of a second
- (c) be accurate to the nearest 10th of a metre for linear measurements;
- (d) be accurate to the nearest minute for angular measurements;
- (e) be surveyed from a vertical benchmark referenced to Geodetic Surveys of Canada based on NAD 83 for ground elevation measurements and be accurate to the nearest 10th of a metre; and
- (f) where the well is located in a water covered area, the location shall be verified with the drilling rig on location.

1.9.2. Deviated and Horizontal Well Location Plans

Operators proposing a horizontal or deviated well shall submit:

- (a) added to the plan view as required by **this section**, the proposed well bore trace, bottom hole latitude and longitude location of the well bore, and the location at which the well bore enters the target formation;
- (b) a cross sectional plan showing the;
 - (i) target geological formation as anticipated by the geological prognosis,
 - (ii) direction of the deviated or horizontal well bore,
 - (iii) kick-off point of the well bore, and
 - (iv) the point(s) of intersection between the well bore and spacing unit target area(s).

1.9.3. Well Bore Surveys

Operators shall conduct deviation and directional surveys on all deviated, horizontal and lateral wells:

- (a) at deviation tests intervals not exceeding 150 metres from the surface casing flange top to the total depth of the well during drilling;
- (b) that are accurate to $\pm 1\%$ of the well depth; and
- (c) submit to the Ministry, the results of the survey including the latitude and longitude of the bottomhole location of the well bore and a final cross section plan and plan view of the well bore, as described in section **1.9.2**, using the actual survey data within 30 days of the well's TD date.

Part 2. Injection Permits

Part 2 applies to wells and projects subject to a permit to inject issued under section 11 of the Oil, Gas and Salt Resources Act. Section 11 permits are required for the purposes of injecting substances into a geological formation in connection with projects set out in that section of the act, including projects for enhancing oil or gas recovery. A section 11 permit is not required for routine well stimulation.

2.1. Application Requirements

Injection permit applications shall be made in writing and accompanied by a report containing the following:

- (a) scaled plan of the lands underlain by the formation that will be the subject of the proposed injection showing:
 - (i) geographic lots and concessions of the area and the boundary of the area proposed to be injected or affected by the injection,
 - (ii) the location and status of all wells including the proposed injection and production wells, and
 - (iii) the boundaries of any designated gas storage areas within 1.6 kilometres from the boundaries shown under (i);
- (b) a feasibility study that addresses the engineering and geological aspects of the project including,
 - (i) a site plan of surface facilities including wells, pipelines, storage tanks and other production facilities,
 - (ii) geological and structural maps illustrating the extent of the formation or pool to be injected,
 - (iii) an isopach map of the of the injection formation,
 - (iv) representative geological cross sections of the injection formation that show the fluid contacts,
 - (v) the production and pressure history of the pool,
 - (vi) a tabulation of reservoir parameters,
 - (vii) a determination of the oil and gas in-place, remaining reserves under existing production practice and the incremental reserves under the proposed injection practice and recovery factors,

- (viii) a forecast of fluid volumes proposed to be injected, produced and re-injected and corresponding gas-oil and water-oil ratios and comparison to existing ratios,
 - (ix) descriptions and results of preliminary injectivity tests,
 - (x) schematics of well completions for all wells proposed to be used or converted to injection,
 - (xi) the location of any observation wells,
 - (xii) a construction schedule including anticipated start-up date; and
- (c) an evaluation of the compatibility of the proposed injection fluid with the fluids and rock type of the injection formation including,
- (i) a description and chemical composition of all fluids,
 - (ii) the source and treatment of injection fluids, and
 - (iii) analyses of fluid-fluid **and fluid**-rock reactions.

2.1.1. Application Fee

The application fee shall be in the form of a money order, cash, cheque or pre-authorized debit from an account or credit card, or credit or debit card payable to the Minister of Finance, and submitted with the Injection permit application.

2.1.2. Incomplete Applications

Incomplete applications will not be processed until missing information is provided.

2.2. Injection Well Design

Operators shall design injection wells to:

- (a) permanently isolate and protect all potable water formations from contamination;
- (b) prevent the migration of the injected fluid from the target formation to other existing and potential hydrocarbon bearing formations;
- (c) prevent the migration of fluids between permeable formations; and
- (d) ensure that the injection fluids do not enter formations other than the injection formation.

2.3. Injection Well/Project Construction, Operation & Maintenance

The operator shall construct, operate and maintain an injection well in a manner that provides for:

- (a) all injection of fluid to be conducted through tubing;
- (b) the annular space between the tubing and production casing to be isolated from the injection zone by a packer or some other acceptable method;
- (c) all fresh water zones to be isolated with casing and cement;
- (d) the surface and production casings to be cemented to surface except when intermediate casing(s) is used;
- (e) when intermediate casing is used, the surface casing and the intermediate casing shall be cemented to the surface and the production casing shall be cemented to surface inside the intermediate casing;
- (f) all wellhead components to be rated to 110 percent of the maximum operating pressure; and
- (g) ensure that the injection fluids are compatible with the injection formation such that precipitates or clay mobilization or other adverse chemical reactions are minimized.

2.4. Existing Well Conversions

Conversion of an existing well for use an injection well may be made if the:

- (a) well is less than 20 years old;
- (b) well's condition and construction meets the requirements of section 2.2; and
- (c) operator conducts additional pressure tests, casing evaluation logs and cement evaluation logs to demonstrate the mechanical integrity of the well.

*Note: Departures from the age limitation in (a) will not be accepted.

Part 3. Well Drilling

The following drilling standards apply to conventional rotary and cable-tool drilling techniques.

Where other publications are referenced within this Part, the reference shall be read as a reference to the most current edition of the publication in effect, including all published amendments.

3.1. General

The operator shall:

- (a) ensure that all casing, tubing and equipment used in the drilling of a well is in good condition and adequate for the depths to be drilled and the pressures that may be encountered;
- (b) plan and effect a casing and cementing program for the well to protect all fresh water horizons and all potential oil-bearing or gas-bearing horizons penetrated during drilling operations and to prevent the migration of oil, gas or water from one horizon to another;
- (c) ensure that all fluid produced or recovered from a well during drilling operations is handled and disposed of in a manner that will not interfere with the rights of any person; and
- (d) ensure that oil field fluid, oil, fuel or any flammable products and refuse from a well or used during the drilling of a well are not handled or disposed of so as to,
 - (i) create or constitute a hazard to public health or safety,
 - (ii) run into or contaminate any fresh water horizon or body of water or remain in a place from which it might contaminate any fresh water or body of water, or
 - (iii) run over or damage any land, road, building or structure.

3.1.1. Restricted Drilling Areas

No person shall drill a well having a surface location:

- (a) within 50 meters of any high voltage power line, road allowance, railway, transmission pipeline or other utility right of way;

- (b) within 75 meters of any dwelling, agricultural, commercial or industrial building, school, church or place of public assembly;
- (c) on land, within 100 meters of the shoreline of any of the Great Lakes including the interconnecting waterways and 30 meters from any other lake, river, stream or municipal drain; and
- (d) in the water covered areas of Lake Erie,
 - (i) within 800 meters of the shore-line, and
 - (ii) within 800 meters of the International Boundary.

Note: Operators must comply with federal and municipal height and setback requirements for well locations on properties located adjacent to airports.

3.1.2. Drilling Rig Set Backs

The location of the drilling and associated equipment used at the well site shall be spaced in accordance with the distances specified in Part 5.

3.1.3. Internal Combustion / Diesel Engines

See Part 5, sections 5.5.4, 5.5.4.1, 5.5.4.2.

3.2. Drill Sump / Pit

Prior to spudding the operator shall:

- (a) construct earthen sumps, reserve pits and mud circulation pits as required; or
- (b) provide tanks for such purposes.

3.2.1. Sump / Pit Construction

Where earthen pits or sumps are constructed the operator shall:

- (a) provide temporary fencing around the sump;
- (b) install an impervious liner when:
 - (i) the depth to groundwater is within 2 metres of pit bottom, or
 - (ii) where ground conditions are other than clay, and
- (c) ensure that fluid levels do not rise above 0.5 metres below grade.

3.2.2. Sump / Pit Liners

Where liners are used in earthen sumps or pits:

- (a) the liner shall be at least 20 mil (0.508 mm) thick virgin polyvinyl chloride or equivalent;
- (b) the bottom and the sides of the pit shall be free of objects that could penetrate the liner;
- (c) ample liner material shall be used to allow for sags and material loading to reduce stress on the liner;
- (d) the bottom of the lined pit shall be weighted with earthen material or water before anchoring the ends of the liner on the surface or placing drilling mud in the pit; and
- (e) where liners become torn, punctured or perforated the operator shall repair the liner in accordance with manufacturer's recommended procedures or replace the liner.

3.3. Sump / Pit Closure

The operator shall close earthen sumps within six months of the TD date of the well.

3.4. Drilling Program Design

The operator shall ensure that the drilling program design:

- (a) protects the public and the environment;
- (b) permanently isolates and protects all potable water formations from contamination;
- (c) isolates potential hydrocarbon-bearing formations from contamination caused by the migration of fluids from other permeable formations;
- (d) prevents the migration of fluids between permeable formations and uncontrolled flow of fluids to surface or subsurface; and
- (e) prevents shale and unconsolidated material from falling into the open hole during the drilling process.

3.5. Design of Casing Program

Casing design, for each stage of drilling operations, shall consider the following:

- (a) the type of well service (e.g. sour, sweet, corrosive);
- (b) the intended purpose of the well;
- (c) the anticipated life span of the well;
- (d) the location and flow characteristics of potential fresh water zones;
- (e) the burst and collapse pressures that may be experienced during cementing operations on the casing string;
- (f) the potential formation pressures that may be encountered during drilling operations and during subsequent production or injection operations;
- (g) the tensile loading placed on the casing body and casing joints during running and cementing operations, especially if pipe is to be reciprocated;
- (h) the pressure exerted on the inside of the casing during pressure integrity tests and formation stimulation operations;
- (i) the need for corrosion allowance where corrosive formation fluids may be produced or may be in contact with the casing;
- (j) the internal drift diameter of the casing relative to the outside diameter of the drill bit to be used in subsequent drilling operations;
- (k) the reduction in casing joint strength due to bending forces in deviated or horizontal wells;
- (l) the internal body wear on the casing string due to drill pipe rotation or cable movement during subsequent drilling operations, especially in deviated or horizontal wells;
- (m) the temporary or permanent nature of the casing installation; and
- (n) the plugging requirements of Part 11 and the method of plugging the well.

3.5.1. Casing Removal

An operator shall not pull or strip a string of casing from a well, except where:

- (a) provision is made for the removal of casing in the drilling program specified in the well licence application;
- (b) casing is pulled and reset in the same formation to obtain a satisfactory casing seat;

- (c) a well is plugged back or plugged to surface; or
- (d) the annular space left open and the formation exposed by the pulling and stripping of casing is sealed.

3.5.1.1. Casing Removal - Producing Wells

Where a well is a producing well, the operator shall ensure that:

- (a) strings of casing intermediate between the producing casing and the surface casing are not recovered unless all horizons containing oil, gas or water are cemented off, and the surface casing is not recovered.

3.5.2. Hole Size

For the purposes of proper sealing of a well, the hole size for a given casing shall be as follows:

Casing Size (O.D. mm)	Hole Size (mm) Cable Tool Drilled Wells	Hole Size (mm) Rotary Drilled Wells
Up to 177.8 O.D.	Casing O.D. + 16	Casing O.D. + 38.1
Greater than 177.8 O.D.	Casing O.D. + 33	Casing O.D. + 50.8
Greater than 273.05 O.D.	N/A	Casing O.D. + 76.2

3.5.3. Annular Clearance

The operator shall design all well casing such that annular clearance between casings is not less than 12 mm for cable tool drilled wells and 25 mm for rotary drilled wells measured from the I.D. of the outer casing to the O.D. of the inner casing as shown below:



3.6. Used Casing

Where an operator proposes to install used casing in a well the operator shall:

- (a) determine and record the history of used casing including the supplier or manufacturer, manufacturer's specifications, and the previous application(s) of the casing;
- (b) examine the condition of the threads on the pipe and inside the collars prior to use in the drilling operations;
- (c) examine the condition of the pipe near the threads and near the casing collars to detect power tong damage and oval distortion;
- (d) conduct spot casing wall thickness measurements on every joint of casing;
- (e) conduct a hydrostatic pressure test to 110% of the maximum anticipated pressure during drilling, completion or production of the well to be held for 5 minutes;
- (f) not install used casing that is greater than 20 years old; and
- (g) provide for an Examiner to certify that all used casing has been inspected and tested in accordance with this section and is appropriate for its proposed use in the well.

3.7. Casing Installation

The operator shall:

- (a) guide casing into the hole using guide shoes, mule shoes, Texas shoes, or centralizers;
- (b) apply the correct makeup torque or thread standoff for the casing;
- (c) clean threads and examine casing on location prior to installation;
- (d) examine for and clear all casing of internal obstructions;
- (e) use thread compound on the casing joints; and
- (f) pressure test the integrity of all joints in the string either prior to or during primary cementing operations.

3.8. API Standards

Operators shall adhere to the following American Petroleum Institute (API) guidelines in the design and installation of intermediate and production casings:

- (a) API Spec 5CT, Specifications for Casing and Tubing.
Note: This document lists chemical compositions, mechanical properties, testing requirements, and dimensional data for API certified casings.
- (b) API TR 5C3, Calculating Performance Properties of Pipe Used as Casing or Tubing.
Note: This document tabulates collapse and internal yield pressures, and joint strengths for API certified casings and tubing.
- (c) API RP 5A5, Field Inspection of New Casing, Tubing, and Plain-end Drill Pipe.
Note: This document lists methods of field inspection of tubular goods.
- (d) API RP 5C1, Recommended Practice for Care and Use of Casing and Tubing.
Note: This document covers recommended procedures for transportation, storage, handling, reconditioning, and installation of casing and tubing.
- (e) API BUL 5C4, Bulletin on Round Thread Casing Joint Strength with Combined Internal Pressure and Bending.

3.9. Design of Cementing Program

The cementing program shall be designed in conjunction with the casing program to permanently prevent fluid migration between porous and permeable formations and shall protect all:

- (a) potable water formations;
- (b) potential hydrocarbon-bearing zones; and
- (c) casings from all fluid bearing formations.

3.9.1. Design Considerations

The operator shall consider the following when designing the cementing program:

- (a) the effect of different lithologies in the well bore;
- (b) the presence of soluble salts such as halite, sulphates such as anhydrite and gypsum, unconsolidated or fractured material, and sloughing shales;
- (c) lost circulation zones;

- (d) anticipated formation pressures;
- (e) bottom hole temperatures;
- (f) gas migration;
- (g) corrosive formation fluids;
- (h) quality and temperature of mix water;
- (i) cement contamination by bore hole fluids;
- (j) casing centralization;
- (k) casing movement during cementing operations; and
- (l) casing displacement.

3.9.2. Cement Quality

The operator shall:

- (a) meet API Spec 10A, **Specification for Cements and Materials for Well Cementing**;
- (b) comply with API Spec 10A, **Specification for Cements and Materials for Well Cementing**, for selecting the correct cement grade and ensuring that the cement is mixed and pumped correctly; and
- (c) provide an Examiner on site during all cementing operations including cement squeezes, remedial cementing, etc. to witness and certify that proper cementing practices were followed.

3.10. Conductor Casing for Shallow Water

Conductor casing shall be run where water flows occur close to the surface.

3.10.1. Conductor Casing for Cable Tool Operations

The operator of a well being drilled using cable tool drilling equipment shall:

- (a) ensure that conductor casing is of sufficient weight and quality to withstand driving force to the bedrock;
- (b) after the conductor casing has been run, ensure the hole is bailed dry and monitored for at least 15 minutes to ensure the flow of fresh water has been shut off prior to the resumption of drilling;

- (c) where the conductor casing has not stopped the water flow into the well bore, squeeze cement to isolate the fresh water zone(s); and
- (d) not recover conductor casing prior to cementing in the next casing string.

3.11. Drilling Surface Hole - Casing and Cementing

Surface casing and cement shall:

- (a) permanently isolate and protect all sources of potable water from other formations which contain non-potable fluids;
- (b) prevent cross-flow between different fresh water aquifers or any fluid bearing zone;
- (c) prevent the sloughing of unconsolidated material into the well bore; and
- (d) be capable of anchoring the well control equipment.

3.11.1. Surface Casing - Cable Tool Drilled Wells

Surface casing shall be cemented to the surface except where:

- (a) there are no shows of water, hydrocarbons or brines in the open hole below the conductor casing;
- (b) the conductor casing is not leaking;
- (c) flows of hydrocarbon or artesian water are not expected in the next segment of the well; or
- (d) one set of casing is cemented across all fresh water zones.

In the cases listed above, surface casing may be set on a casing shoe.

3.11.2. Surface Casing - Rotary Drilled Wells

The surface hole shall be drilled sufficiently deep into bedrock to:

- (a) secure cemented casing to bedrock;
- (b) be 15 metres into non-porous competent bedrock and 15 metres below the lowest potable water zone if that water is encountered in bedrock; or
- (c) below all potable water zones yet above non-potable water zones if 15 metres is not available between the potable and non-potable water zones.

3.11.3. Artesian Water

If artesian fresh water flow is expected in a well, a string of casing shall be run above the artesian fresh water zone so that the flow of water can be controlled. A second string shall be run and set below the artesian fresh water zone in order to isolate it from underlying porous formations containing non-potable fluids.

3.11.4. Surface Casing Cementing

Surface casing shall be cemented before formations containing non-potable fluids are drilled except where the requirements of section 3.11.1 are met for cable tool operations. Where surface casing is cemented it shall be:

- (a) cemented full length from total depth to surface;
- (b) using cement volumes based on caliper volume if available or theoretical annular hole volume plus the volume of the shoe joint plus;
 - (i) 50% excess cement if cement volume is based on theoretical calculation, or
 - (ii) 20% excess if cement volume is based on a caliper volume; and
- (c) cemented using the circulation method.

3.11.5. Cement Monitoring

During the cementing operations, the annular flow shall be monitored for cement returns to surface. If the cementing operation does not obtain isolation of the fresh water, remedial cementing shall be done in accordance with section 3.13.12.

3.11.6. Cement Quality

Surface casing cement shall be sulphate-resistant if sulphur-bearing fluids are anticipated in the next segment of a well. (Refer to **API Spec 10A, Specification for Cements and Materials for Well Cementing** and mill grind of cement to confirm sulphate resistance of cement.)

3.11.7. Cementing Procedure

The surface casing cement shall be under-displaced to retain 5 metres of contaminated tail cement.

3.11.8. Pre-Flush

If the surface hole is drilled using viscous drilling mud, a pre-flush shall be circulated to remove mud and filter cake before the surface casing is cemented.

3.11.9. Slurry Samples

Slurry samples shall be obtained during the start, middle and end of the cementing operation to observe set-up time, curing time, and to estimate the compressive strength of the cement prior to drill-out.

3.11.10. Wait on Cement (WOC)

The operator shall collect cement samples while cementing and use them as a guide to determine sufficient WOC time. Drill-out operations shall not commence until the cement samples exhibit a compressive strength of 3600 kPa as determined by cement tables and visual examination.

3.11.11. Casing Pressure Test

A pressure test shall be conducted on the casing before the cement is drilled out of the shoe joint. If the casing fails the pressure test, the problem shall be identified and remedial work shall be undertaken before drilling operations are continued.

3.11.12. Pressure Integrity Test (PIT)

After the cement in the shoe joint and a maximum of 0.5 metre of new formation have been drilled, the operator shall conduct a PIT:

- (a) using a low volume, high pressure pump and apply a pressure on the formation equivalent to a gradient of 18 kPa per metre but in no case shall the pressure applied be greater than pressure capable of forcing drill pipe out of the hole;
- (a) for a duration of ten (10) minutes;
- (b) using an incompressible fluid to apply the pressure for the test; and
- (c) recording and retaining on file the following information:
 - (i) type of fluid used and its gradient (kPa/metre),
 - (ii) test duration,
 - (iii) initial pressure, and
 - (iv) final pressure.

3.11.13. Pressure Integrity Test (PIT) Failure

If the surface casing seat does not hold pressure, the operator shall rectify the problem before drilling operations are continued.

3.12. Drilling Intermediate Hole - Casing and Cementing

Intermediate casing and cement shall be used to:

- (a) protect equipment and shallower formations from excessive pressures;
- (b) permanently prevent fluid migration between porous and permeable formations;
- (c) prevent the shales and unconsolidated material from falling into the open hole; and
- (d) control the maximum anticipated target zone pressure.

3.12.1. First Control String

The intermediate casing comprising the first control string shall be set and cemented prior to drilling into the target zone.

3.12.2. Aquifer Present

Where an aquifer is present in the intermediate hole, the next string of casing shall be cemented in place.

Note: In many areas of Ontario more than one aquifer may be encountered in the intermediate hole.

3.12.3. Isolation

The operator shall:

- (a) identify all oil, gas and fluid bearing zones during the drilling of a well;
- (b) pump sufficient cement to separate all oil, gas and fluid bearing zones from each other and from the previous casing string;
- (c) where more than one oil, gas or fluid bearing zones is present behind a string of casing, ensure that cement in the casing annulus rises 25 metres above the top of the oil, gas or fluid bearing zones that is encountered below the base of the previous casing; and

- (d) where good cement returns are not received at surface, identify the top of cement in the casing annulus and provide for an Examiner to certify isolation of all porous zones.

3.12.4. Lost Circulation

If lost circulation is expected or detected in the drilling of an intermediate hole, the operator shall take necessary measures to isolate the lost circulation zone from any other porous zone encountered in the drilling of the well by:

- (a) sealing the zone prior to or during the cementing of the casing designed to cover the zone; or
- (b) if a zone of lost circulation is identified during drilling operations, the operator may plug off this zone immediately.

3.12.5. Cementing

The intermediate casing shall be cemented by the circulation method with sufficient cement volume to theoretically reach to at least 25 metres above the casing seat of the previous casing string.

3.12.5.1. Cement Monitoring

If the cementing operation does not obtain isolation of all porous zones, remedial cementing shall be done in accordance with section 3.13.12.

3.12.6. Cement Volume

Cement volume shall be based on caliper volume if available or theoretical annular hole volume plus the volume of the shoe joint plus:

- (a) 30% excess cement if cement volume is based on theoretical calculation; or
- (b) 20% excess up to the designed cement top if cement volume is based on a caliper volume

3.12.7. Cement Quality

Intermediate casing cement shall be sulphate-resistant if sulphur water zones have been penetrated in the intermediate hole. (Refer to **API Spec 10A, Specification for Cements and Materials for Well Cementing** and the mill grind analysis of cement to confirm sulphate-resistance of cement).

3.12.8. Cementing - Shoe Joint

A shoe joint with a length of five metres shall be run to retain contaminated tail cement.

3.12.9. Wait on Cement (WOC)

WOC time shall be 6 hours. Drill-out operations shall not commence until the cement sample exhibits a compressive strength of 3600 kPa as determined by cement tables and visual examination.

3.12.10. Casing Pressure Test

A pressure test shall be conducted on the casing before the cement is drilled out of the shoe joint. The pressure test shall consist of:

- (a) a low pressure test of usually 1400 kPa; and
- (b) a high pressure test where the surface pressure for the high pressure test shall be 110% of the maximum anticipated formation pressure in the next segment of the well.

If the pressure test fails, the problem shall be identified and remedial work shall be undertaken before drilling operations are continued.

3.12.11. Pressure Test - Cable Tool

For cable tool operations, the spool, casing valve and BOP equipment on the wellhead shall be installed and tested to a pressure specified in the drilling program in conjunction with the static pressure test on the intermediate casing string.

3.12.12. Pressure Integrity Test (PIT)

After the cement in the shoe joint and a maximum of one half-metre (0.5m) of new formation have been drilled, the operator shall conduct a PIT:

- (a) using a low volume, high pressure pump;
- (b) applying pressure on the formation at a pressure equivalent to a gradient of 18 kPa per metre or the expected reservoir pressure;
- (c) for a duration of ten (10) minutes;
- (d) using an incompressible fluid to apply the pressure for the test; and
- (e) recording and retaining on file the following information:

- (i) type of fluid and its gradient (kPa/metre),
- (ii) test duration,
- (iii) initial pressure, and
- (iv) final pressure.

3.13. Drilling Main Hole - Casing and Cementing

Cemented production casing shall protect equipment and formations from anticipated pressures and permanently prevent fluid migration between porous and permeable formations.

3.13.1. Logs for Exploratory Wells

Within 30 days of the well's TD date, the operator of a well classed as exploratory shall run a:

- (a) gamma ray log from the top of the bedrock to the TD; and
- (b) a neutron log through the vertical and deviated sections of the wellbore from the top of the bedrock to the start of the horizontal section of the wellbore or TD, as the case may be.

3.13.2. Wellhead Equipment – Drilling

The operator shall ensure that all valves, nipples, casing and tubing spools, casing and tubing bowls, and changeover flanges and spools installed below the BOP on the wellhead after the last intermediate casing (or surface casing if no intermediate casing) has been installed, comply with **API Spec 6A, Specification for Wellhead and Tree Equipment**.

3.13.3. Blowout Prevention (BOP)

The Blowout Prevention (BOP) System for well control shall be installed in accordance with Part 4 and pressure-tested in conjunction with the pressure test of the last string of intermediate casing.

3.13.4. Cable Tool Well Control Equipment

- (a) Prior to drilling of a formation with potential for the flow of natural gas or crude oil, a well control device shall be installed that is;
 - (i) capable of closing around the cable and on the open hole, and

- (ii) which can be controlled from a remote location;
- (b) The well control device shall be function tested daily during the drilling operations.
- (c) All the components of the lubricator system assembly shall be capable of handling at least 120% of the maximum anticipated pressure.
- (d) The operator shall specify in the drilling program when a full lubricator system shall be employed.
- (e) A full lubricator system shall be required when;
 - (i) gas is encountered with H₂S content greater than 100 ppm,
 - (ii) when crude oil flows to surface or is capable of unloading during bailing operations, or
 - (iii) when flows of natural gas exceed $7.0 \times 10^3 \text{m}^3/\text{D}$ (250 Mcfd).

3.13.5. Rotary Well Control Equipment

Well control equipment in addition to the requirements under Part 4 shall be installed when drilling the well under balanced, with air, gas or foam. When a rotating head is installed as a part of this additional well control equipment, it shall be attached directly to the BOP system. The side outlet shall be equal to or larger than the connecting outlet.

3.13.6. Cementing

The top of the cement in the production casing annulus shall be placed inside the previous intermediate casing to a height of 25 metres above the intermediate casing seat; but in every case, not less than 100 metres above the highest potential pay zone. In the case of:

- (a) a corrosive zone behind the intermediate casing that has not been covered with cement, the cement in the production casing annulus shall be sufficient to rise 25 metres above the top of the corrosive zone;
- (b) liners being used, they shall be cemented across their full length;
- (c) disposal and injection well casings, cement tops shall be as outlined in Part 7;
- (d) a well located in a water covered area, the production casing shall be cemented to surface before production commences.

In all cases, the operator shall provide for an Examiner to certify cement tops.

3.13.6.1. Cement Monitoring

If the cementing operation does not obtain isolation of all porous zones, remedial cementing shall be done in accordance with section 3.13.12.

3.13.7. Cement Volume

Cement excess volume shall be:

- (a) 30% if cement volume required is based on theoretical calculation; or
- (b) 20% if cement volume is based on a caliper volume determination.

Note: Theoretical volume calculations shall include the volume of the shoe joint.

3.13.8. Cement Quality

Cement quality across the potential pay zone shall be no less than the classification of neat cement without volume extenders, and:

- (a) the water used to mix cement shall be of a quality and temperature required to achieve maximum compressive strength for the cement; and
- (b) a casing shoe joint with a length of five metres shall be run to retain contaminated tail cement.

3.13.9. Cement Placement

The operator shall place cement:

- (a) by displacement with an appropriate wiper plug to separate the cement from the displacing fluid;
- (b) with a float-type collar, a latch-down type collar, or a baffle plate run above the shoe joint so that a wiper plug can be used to provide a positive stop to cement displacement;
- (c) using a preflush fluid or scavenger cement to remove the drilling fluid and the filter cake and to improve the cement bond before the tail cement is pumped into the casing for rotary drilling operations where viscous drilling fluids have caused filter cake build-up; and
- (d) using wall cleaners or scratchers installed across the pay zone to improve the cement bond if viscous drilling fluid has caused filter cake build-up on the well bore.

3.13.10. Centralizers

Centralizers shall be run at 15 metres above the top and at the base of every porous formation and in no case at intervals greater than 100 metres within the cemented segment of the well.

3.13.11. Lightweight Cement

Lightweight cements may be used to protect formations from excessive hydrostatic pressures and potential lost circulation under the following conditions:

- (a) a sufficient volume of neat tail cement is pumped to place the top of the neat cement at least 50 metres above the uppermost hydrocarbon bearing formation; and
- (b) the tail cement covering the potential pay zone is equal in quality to the classification of neat cement.

3.13.12. Remedial Treatments/Cementing

Remedial techniques shall be used to meet design considerations when unconsolidated formations, sloughing shale, lost circulation and other such conditions are encountered and if there is evidence of communication between permeable formations behind a casing string and where hydrostatic communication is suspected between porous formations.

3.13.13. Cement Bond Log

Where remedial cement squeeze treatment is required a cement bond log shall be run prior to a cement squeeze, to identify the problem, and after the cement squeeze operation, to confirm its effectiveness. The operator shall record and retain on file remedial cementing records including procedures, observations, and pressure test results in full detail.

3.14. Surface Equipment

All valves, tubing and casing heads, and tubing and casing spools installed on the wellhead shall comply with **API Spec 6A, Specification for Wellhead and Tree Equipment**. For solution mining wells valves shall comply with **API Spec 6A, Specification for Wellhead and Tree Equipment** or **CSA B51, Boiler, Pressure Vessel, and Pressure Piping Code**. Prior to completing the well after the production casing has been set and cemented, the operator shall:

- (a) install a casing head or spool with at least two valved and bull plugged side outlets to allow pack-off of the production casing and the intermediate casing annulus in the event that insufficient cement was pumped to isolate all main hole porous zones from the surface during the production casing cement job;
- (b) provide a wellhead to isolate the annulus at the surface or isolate the potential flow of water down hole, if flows of water are possible from outside the intermediate casings; and
- (c) for oil and gas wells where tubing is run in the well, install a tubing head or tubing spool with at least two, valved and bull plugged side outlets.

3.15. Drilling Records

The operator shall record and keep on file the following casing information:

- (a) the size, type, grade, and weight;
- (b) the names of the manufacturer and supplier;
- (c) a casing tally;
- (d) whether the casing was new or used;
- (e) the history of use for used casing;
- (f) setting depth; and
- (g) a description of any operational problems encountered while running the casing into the well including when casing is circulated and, or driven down.

3.16. Cementing Records

The operator shall monitor, record, and retain on file indefinitely the following information pertaining to each cement job:

- (a) name of the cementing company;
- (b) cement blends used including cement type and additives;
- (c) source of the mix water;
- (d) type and volume of any preflush;
- (e) volumes of cement;
- (f) cement slurry density;
- (g) actual displacement volume;

- (h) final displacement pressure;
- (i) any cement movement techniques;
- (j) observation of cement returns including an estimation of the volume of cement returns;
- (k) float equipment and casing attachments;
- (l) results of every pressure test;
- (m) cement tops and how they were identified e.g. by logging;
- (n) a detailed description of any operational problems; and
- (o) a copy of the cement bond logs.

3.17. Daily Records

The operator shall ensure that daily records are kept at the well site during all drilling operations and these records shall include:

- (a) the depth at the beginning of the day or shift;
- (b) the depth at the end of the day or shift;
- (c) the diameter of the hole;
- (d) any change in the casing program;
- (e) if casing is set, its setting depth, casing size, type, grade, weight and whether the casing is new or used;
- (f) a description of all cement jobs performed;
- (g) pressure tests and results;
- (h) the depth at which any showing, however small, of oil, gas or water is encountered and the flows, pressures, and levels thereof;
- (i) the depth or interval of lost circulation zones encountered; and
- (j) a description of any related operations including fishing, stimulating, perforating, acidizing, fracturing, surveying and plugging.

3.18. Drill Cutting and Fluid Samples

The operator, during the drilling of a well, shall:

- (a) collect drill cutting samples from the:
 - (i) vertical or deviated portions of a well bore, taken at intervals not greater than 3 metres, from the top of bedrock to the total depth of the vertical or deviated portion of the wellbore; and
 - (ii) horizontal portion of a well bore, taken at intervals not greater than 6 metres, from the end of the build section of the well to the total depth; and
- (b) prepare the samples by:
 - (i) bagging, drying and accurately labeling the bags with the name of the well and licence number as it appears on the well licence and the corresponding depth interval; or
 - (ii) washing, drying and placing in vials and accurately labeling the vials with the corresponding depth interval and the box of vials labeled with the name of the well and licence number as it appears on the well licence; and
- (c) where the Ministry requests, collect samples of any oil, gas or water recovered from a well.

3.18.1. Reporting

The operator of a well being drilled shall comply with Part 13 for the reporting of the drilling activity notifications, completion information, drill and core samples, well tests and logs.

3.19. Site Rehabilitation

Within six months of the end of every drilling or plugging operation, the operator shall:

- (a) clear the area around the well of all refuse material;
- (b) dispose of all liquid and solid waste in environmentally acceptable and safe manner;
- (c) drain and fill in excavations;

- (d) where the pits contain salt or other chemicals which may inhibit plant growth, clean out such pits before filling;
- (e) remove concrete bases, machinery and materials;
- (f) level and restore the site, as nearly as is possible, to its original condition prior to drilling; and
- (g) provide for an Examiner to visit the site and certify that rehabilitation and plugging of the well was completed in accordance with this Standard.

3.20. Drilling in Water Covered Areas

The operator of a well being drilled in a water covered area shall:

- (a) for wells located in Lake Erie, not commence drilling operations prior to April 1st or after October 31st in any calendar year;
- (b) cement all casings to lake bed;
- (c) continuously monitor for the occurrence of oil and other liquid hydrocarbons;
- (d) plug any well that encounters and is capable of producing appreciable amounts of oil or other liquid hydrocarbons;
- (e) use only fresh water based drilling fluids;
- (f) have onboard tanks to contain all drilling fluids and cuttings in the event that oil or liquid hydrocarbons are encountered and return all such materials to shore for proper disposal; and
- (g) return drill cuttings that are not contaminated by liquid hydrocarbons to the lakebed in a manner that minimizes turbidity.

3.20.1. Emergency Response Plans

Operators conducting drilling and production operations in water covered areas shall prepare, implement and submit a copy of a contingency plan to the Ministry each year before commencing any offshore work. The plan shall include:

- (a) Emergency definitions;
- (b) Written instructions for response and mitigation actions to be taken for:
 - (i) accidents resulting in injury or fatality,
 - (ii) oil, chemical, H₂S or other fluid spill or gas release,
 - (iii) fire or explosion,

Oil, Gas and Salt Resources of Ontario, Provincial Operating Standards

- (iv) loss of well control,
 - (v) collision or near miss incident, and
 - (vi) evacuation or abandon ship;
- (c) Emergency response organization and corresponding responsibilities for actions to be taken.
 - (d) Locations and access routes or directions to all works.
 - (e) Listing and location of resources, personnel, supplies and equipment that are necessary to mobilize in the event of an incident described in item (b);
 - (f) Contact lists and priorities for all relevant company personnel, government agencies and equipment and material suppliers and locations; and
 - (g) Incident assessment and reporting procedures.

3.20.2. Emergency Response Drills

Emergency Response Drills shall be conducted on a regular basis to test the effectiveness of the Emergency Response Plan.

Part 4. Blowout Prevention (BOP)

4.1. Drilling BOP Requirements

The operator of a well being drilled shall ensure that the well has installed thereon and maintained at all times casing and blowout prevention equipment that:

- (a) is adequate to shut off any flow at the well head whether or not any type of tool or equipment is being used in the hole; and
- (b) complies with the well classification set out in section 4.3 and with the specifications set out in Schedule 1.

4.2. Well Specific BOP Requirements

Note: The Ministry may, by condition on a well licence, specify the blowout prevention requirements that apply to a well.

4.3. Well Classes

For the purpose of drilling BOP requirements and the BOP equipment required in Schedule 1, wells are classified as set out below:

- (a) Class A: a well without the first control string of casing set;
- (b) Class B: a well in which the first control string of casing is set and the true vertical depth is not greater than 1800 metres.

4.4. Cable Tool Drilling BOP Requirements

The operator of a well being drilled with a cable tool rig shall ensure that the following BOP requirements are met.

4.4.1. Casing Bowl or Spool

The casing bowl or spool upon which the BOP equipment is attached shall have:

- (a) flanges that are an integral part of the casing bowl or spool, or a thread/flange crossover directly on top of the casing bowl or spool; and
- (b) at least one valve except where a drilling spool has been installed between the casing bowl or spool and the lowest blowout preventer.

4.4.2. Cable Tool Drilling BOP Equipment

- (a) For Class A wells, Schedule 1, page 112 BOP equipment is required.
- (b) For Class B wells, Schedule 1, page 114 BOP equipment is required.

4.4.3. Hydraulic Operation

All components of Class B well BOP's that are hydraulically operated shall be connected to an accumulator system.

4.4.4. Mechanical Operation

The lower-most component of Class B well BOP's may be operated mechanically. Where mechanical operation of blowout preventers is employed the wheel used to close the system shall be located 5 metres outside of the rig floor and the shaft connecting the BOP to the wheel shall be secured to the preventer to prevent disengagement during closing or opening operations.

4.4.5. Accumulator System

Where an accumulator system is used it shall be:

- (a) installed and operated in accordance with the manufacturer's specifications;
- (b) capable of providing, without recharging, fluid of sufficient volume and pressure to open the hydraulically operated valve on the bleed-off line if this valve is hydraulically operated and to effect full closure of all hydraulically operated preventers and to retain a pressure of 8400 kPa on the accumulator system;
- (c) connected to the BOP's and the hydraulically operated valve on the bleed-off line if this valve is hydraulically operated with lines of working pressure equal to the working pressure of the accumulator, and where lines are located under the rig floor, be of steel construction unless completely sheathed with adequate fire resistant sleeving;
- (d) recharged by a pressure controlled pump capable of recovering within 5 minutes the accumulator pressure drop resulting from the operation of the hydraulically operated valve if present and full closure of the annular preventer;
- (e) capable of closing any ram type preventer within 30 seconds using only the accumulator;
- (f) capable of closing any annular type blowout preventer within 90 seconds;

- (g) equipped with readily accessible fittings and gauges to determine the precharge pressure; and
- (h) equipped with a check valve between the accumulator recharge pump and the accumulator.

4.4.6. Nitrogen Supply

The accumulator system shall be connected to a nitrogen supply that is:

- (a) capable of opening the hydraulically operated valve and capable of closing the annular blowout preventer and one ram type preventer;
- (b) at a pressure of not less than 12,500 kPa; and
- (c) has a gauge installed or readily available for installation, to determine the pressure of each nitrogen container.

4.4.7. Ram Type Preventers

Ram type blowout preventers, which are not equipped with automatic ram locking devices, shall have hand wheels either installed or readily accessible for installation.

4.4.8. Hydraulic BOP System Controls

The blowout prevention system shall include operating controls for each hydraulically operated blowout preventer and the hydraulically operated valve if one is installed. These controls shall be located near the driller's position so that access to them is not restricted.

4.4.9. Kill Systems

An inlet below all the BOP's must be available to connect a kill truck or kill pump to, and shall:

- (a) be at least 50 millimetres in diameter;
- (b) for Class B wells, have a nipple and valve installed into the drilling spool, casing bowl or casing head and a kill line attached to the valve and extending at least 10 meters from the well;
- (c) all components of the kill line must have a working pressure rating at least equal to that of the BOP system; and
- (d) the inlet for pumping kill fluids into the well shall have completely separate lines attached to the drilling spool, casing bowl, or casing head.

4.4.10. Bleed Off System

An outlet below all the BOP's shall be available to bleed pressure from the well and shall:

- (a) be at least 50 millimetres in diameter;
- (b) for Class B wells, have:
 - (i) a nipple and valve installed into the drilling spool, casing bowl, or casing head,
 - (ii) a bleed off line that:
 - is attached to the valve,
 - extends at least 10 meters from the well,
 - is equipped to allow the casing pressure to be measured at the end of the bleed off line while pressure is being relieved from the well, and
 - has an adjustable choke installed to allow for the controlled release of pressure from the well;
- (c) have a working pressure at least equal to that of the BOP system for all components of the bleed off line; and
- (d) have completely separate lines attached to the drilling spool, casing bowl, or casing head.

4.4.11. Flexible Hose

A flexible hose may be installed in place of a steel kill or bleed off line provided that the hose:

- (a) has a pressure rating equal to that of the BOP system;
- (b) has the same internal diameter as the steel line;
- (c) has factory installed connections;
- (d) is sheathed to provide an adequate fire resistant rating;
- (e) is marked so that its manufacturer can be readily identified;
- (f) does not contain bends with a radius less than the manufacturer's specified minimum bending radius;
- (g) is secured to prevent stresses on connection valves and piping, and is protected from mechanical damage; and

- (h) is shop serviced and shop tested to its working pressure at least once every three years and the test data and maintenance performed shall be recorded and made available to the Ministry upon request.

4.4.12. Pressure Tests

For Class B wells, each component of the BOP system shall be pressure tested in conjunction with the casing pressure test prior to drilling the cement out of the previous casing string. The operator shall not proceed with any drilling operations until the pressure test of the BOP system has been successfully completed.

4.4.13. Function Testing of BOP's

The operator of a well being drilled shall ensure that the appropriate blowout prevention equipment is mechanically tested at least daily and any equipment found defective shall be made serviceable before operations are resumed.

4.4.14. BOP Servicing

At least once every three years all blowout preventers shall be shop serviced and shop tested to their working pressure and the test data and maintenance performed shall be recorded and made available to the Ministry upon request.

4.4.15. Rig Crew Training

The operator of a well shall at all times ensure that:

- (a) the rig crew is trained in the operation of the BOP equipment;
- (b) the driller has a First Line Supervisor certificate issued within the previous three years by the Petroleum Industry Training Service or equivalent in blowout prevention and kick control procedures;
- (c) at least one person who has a Second Line Supervisor certificate issued within the previous two years by the Petroleum Industry Training Service in well control procedures is readily available;
- (d) blowout prevention drills are performed prior to drilling out the first control casing string casing shoe;
- (e) blowout prevention drills are performed by each drilling crew every seven days;
- (f) drills performed in accordance with clauses (d) and (e) are recorded in the drilling log book; and

- (g) the procedures, calculations, formulae and current data needed to control a kick at a well are clearly posted at the rig.

4.5. Rotary Drilling BOP Requirements

The operator of a well being drilled with a rotary drilling rig shall ensure that the following BOP requirements are met.

4.5.1. Rotary BOP Equipment

- (a) For Class A wells, Schedule 1, page 113 BOP equipment is required.
- (b) For Class B wells, Schedule 1, page 115 BOP equipment is required.

4.5.2. Drill Through Components

Drilling-through components installed between the top flange of the uppermost blowout preventer element and the rotary table shall be constructed so as to permit their removal while drill pipe or other equipment is in the drilled hole. This section does not apply to drilling operations utilizing a rotating head.

4.5.3. Casing Bowl

The casing bowl shall have:

- (a) the flange as an integral part of the casing bowl; and
- (b) at least one valve, except where a drilling spool has been installed between the casing bowl and the lower ram type blowout preventer.

4.5.4. Hydraulic Operation

All blowout preventers shall be hydraulically operated and, except for wells in Class A, shall be connected to an accumulator system.

4.5.5. Accumulator System

Where an accumulator system is used it shall be:

- (a) installed and operated in accordance with the manufacturer's specifications;
- (b) capable of providing without recharging, fluid of sufficient volume and pressure to open the hydraulically operated valve on the bleed-off line, to effect full closure of the annular preventer and to retain a pressure of 8400 kPa on the accumulator system;

- (c) connected to the blowout preventers and the hydraulically operated valve on the bleed-off line with lines of working pressure equal to the working pressure of the accumulator, and where lines are located under the substructure, be of steel construction unless completely sheathed with adequate fire resistant sleeving;
- (d) recharged by an automatic, pressure controlled pump capable of recovering within 5 minutes the accumulator pressure drop resulting from the operation of the hydraulically operated valve and full closure of the annular preventer;
- (e) capable of closing any ram type blowout preventer within 30 seconds using only the accumulator;
- (f) capable of closing any annular type blowout preventer of a size up to and including 350 millimetres within 60 seconds;
- (g) capable of closing any annular type blowout preventer of a size greater than 350 millimetres within 90 seconds; and
- (h) equipped with readily accessible fittings and gauge to determine the precharge pressure.

4.5.6. Nitrogen Supply

The accumulator system shall be connected to a nitrogen supply that is:

- (a) capable of opening the hydraulically operated valve and capable of closing the annular blowout preventer and one ram type preventer;
- (b) under a pressure of not less than 12,500 kPa; and
- (c) have a gauge installed or readily available for installation, to determine the pressure of each nitrogen container.

4.5.7. Ram Type Preventers

Ram type blowout preventers, which are not equipped with automatic ram locking devices, shall have hand wheels either installed or readily accessible for installation.

4.5.8. BOP System Controls

The blowout prevention system shall include:

- (a) operating controls for each blowout preventer and the hydraulically operated valve on the bleed-off line, located near the driller's position so that access to them is not restricted; and
- (b) an additional set of operating controls that are:
 - (i) capable of closing each blowout preventer and opening the hydraulically operated valve on the bleed-off line,
 - (ii) located at least 15 metres from the well, and
 - (iii) readily accessible and shielded or housed to protect the operator from the flow from the well.

4.5.9. BOP Kill System

The blowout prevention system, except for wells in Class A, shall include a kill system for the purpose of pumping fluid into the well that:

- (a) consists of an arrangement of valves and steel lines which have a working pressure equal to that of the blowout prevention system specified in Schedule 1 for the applicable class of well;
- (b) have a kill line connecting the mud line to the drilling spool;
- (c) be valved to isolate the kill line from the stand pipe;
- (d) have two flanged valves installed on each drilling spool; and
- (e) have lines of at least 50 millimetres nominal diameter.

4.5.10. Flexible Hose

A flexible hose may be installed in place of the steel kill line provided that the hose:

- (a) has a pressure rating equal to that of the blowout preventer system;
- (b) has the same internal diameter as the steel line;
- (c) has factory installed connections;
- (d) is sheathed to provide an adequate fire resistant rating;
- (e) is marked so that its manufacturer can be readily identified;
- (f) does not contain bends with a radius less than the manufacturer's specified minimum bending radius;
- (g) is secured to prevent stresses on connecting valves and piping, and is protected from mechanical damage; and

- (h) is shop serviced and shop tested to its working pressure at least once every three years and the test data and maintenance performed shall be recorded and made available to the Ministry upon request.

4.5.11. Class B Bleed-Off System

The blowout prevention system shall include a bleed-off system for the purpose of bleeding off well pressure and an accurate pressure gauge and other necessary equipment must be installed or readily accessible for installation on the stand pipe or other suitable connection to provide the drill pipe pressure at the choke control location. The bleed-off system shall:

- (a) consist of an arrangement of valves, chokes and steel lines which have a working pressure equal to that of the blowout prevention system specified in Schedule 1 for the applicable class of well, except that part of the bleed-off line downstream from the last valve on the bleed-off manifold;
- (b) contain only straight pipe or 90 degree bends constructed of tees and crosses blocked on fluid turns; and
- (c) be securely tied down.

4.5.12. Class A Bleed-Off System

The bleed-off system for wells in Class A shall consist of:

- (a) a line having a nominal diameter of 75 millimeters, containing a quick opening valve and terminating in an earthen pit at least 30 meters from the well when drilling with mud; or
- (b) a line having a nominal diameter of 100 millimeters and terminating in an earthen pit at least 30 meters from the well when drilling with air.

4.5.13. Spool to Manifold Bleed-Off Line

The section of bleed-off line connecting the drilling spool to the choke manifold shall:

- (a) have a nominal diameter of at least 75 millimetres;
- (b) be connected by flanges or high pressure hammer unions and conform to the requirements specified in section 4.5.12;
- (c) contain 2 flanged valves installed on the drilling spool, one of which must be hydraulically operated, and where 2 spools are installed the hydraulically operated valve shall be connected to the upper spool; and

- (d) where a flexible hose is installed in the section of bleed-off line connecting the drilling spool to the choke manifold, it shall conform to the requirements specified in section 4.5.10.

4.5.14. Choke Manifold

The choke manifold shall:

- (a) be constructed in conformance with the requirements of section 4.5.11;
- (b) permit the flow from the well to be diverted to;
 - (i) the flare pit through a 75 millimetre minimum nominal diameter line, and
 - (ii) a mud system line and a flare pit line through two 50 millimetre minimum nominal diameter choke lines;
- (c) contain two adjustable chokes, one in each choke line, valves to isolate each choke;
- (d) be constructed with a valved outlet located so that regardless of which line is in use, the casing pressure can be monitored by an accurate pressure gauge which shall be either installed or readily accessible for installation;
- (e) be equipped so as to provide the casing pressure at the choke control where a remotely operated choke is installed;
- (f) be constructed to provide the flow paths illustrated in Schedule 1, although not necessarily conforming to the exact configurations there shown;
- (g) be located outside the substructure, readily accessible; and
- (h) be protected from freezing.

4.5.14.1. Manifold - Mud System Line

A line from the manifold to the mud system shall:

- (a) be connected to each choke line;
- (b) be at least the same nominal diameter as the choke lines; and
- (c) direct the flow to a mud tank through a mud-gas separator except where the pump suction is taking fluid from earthen pits.

4.5.14.2. Choke Manifold Bleed-Off Line

The section of bleed-off line downstream from the last valve on the choke manifold to the flare pit shall:

- (a) have a nominal diameter of at least 75 millimetres;
- (b) extend at least 30 metres from the well and be securely tied down; and
- (c) terminate in a slightly downward direction into an earthen pit which shall:
 - (i) be excavated to a depth of not less than 1 metres,
 - (ii) have side and back walls rising not less than 1 metres above ground level, and
 - (iii) be shaped to contain the liquid.

4.5.14.3. Auxiliary Bleed-Off Lines

Auxiliary bleed-off lines, where installed, shall be the same nominal diameter as the lines being extended and conform to the requirement of section 4.5.14.2.

4.5.15. Mud Tanks

Where a mud tank is in service, the operator shall:

- (a) install and maintain a mud-gas separator connected to a separate flare line with a diameter of at least 25 millimetres larger than the inlet line and terminating in an earthen pit 30 metres from the well; and
- (b) install and maintain a device or method to provide warning at the driller's position of a change of the level of fluid in the mud tank or of an imbalance in the volume of fluids entering and returning from the well.

4.5.16. Drilling Fluid Volume

The drilling mud system shall be equipped with a device to accurately measure the volume of drilling fluid required to fill the hole while pulling the pipe from the well.

4.5.17. Pulling Pipe

The operator, while pulling pipe from a well, shall ensure that the:

- (a) hole is filled with drilling fluid at sufficiently frequent intervals so that the fluid level in well bore does not fall below a depth of 30 metres; and
- (b) volume of fluid is recorded each time the hole is filled.

4.5.18. Cold Weather

During cold weather operations, the operator shall ensure that:

- (a) sufficient heat is provided or maintained to the blowout preventer stack and associated valves, kill system, and accumulator system and choke manifold to maintain their effectiveness; and
- (b) all lines in the bleed-off system, including those sections between the blowout preventers and the choke manifold, are:
 - (i) empty,
 - (ii) filled with a non-freezing fluid that is miscible with water, or
 - (iii) heated.

4.5.19. Drill String Safety Valve (Stabbing Valve)

The operator shall maintain on the drilling rig in a readily accessible location a full opening drill string safety valve in the open position and a device capable of stopping back-flow if one is not installed in the drill string, both of which can be stripped into the well when installed in the drill pipe or drill collars.

4.5.20. Air, Gas or Foam Drilling

Where a well is being drilled with air, gas or foam the operator shall:

- (a) install and maintain;
 - (i) in addition to the blowout prevention equipment required in Schedule 1, a rotating head that diverts the flow during the period the well will be drilled with air;
 - (ii) a diverter line not less than 30 metres in length;
 - (iii) a reserve volume of drilling fluid equal to at least 1.5 times the capacity of the hole;
 - (iv) when drilling formations that may contain hydrogen sulphide, a continuous hydrogen sulphide monitor on the diverter line; and
- (b) flare any gas flowing from the end of the diverter line.

4.5.21. Pressure Tests

Before drilling out the casing shoe, the operator shall ensure that a ten minute pressure test is conducted on the casing and on:

- (a) each ram type blowout preventer prior to drilling the cement out of the surface, intermediate and production casing, to 1400 kilopascals with a low viscosity fluid, and the test shall be conducted prior to each ram type test described in clauses (b) and (c),
- (b) each ram type and annular blowout preventer and the bleed-off manifold prior to drilling the cement out of the surface casing, to 3500 kilopascals or to a pressure numerically equivalent in kilopascals to 25 times the setting depth in metres of the first control string, whichever is the lesser;
- (c) each ram type blowout preventer and the bleed-off manifold prior to drilling the cement out of the intermediate and production casing to a pressure equivalent to the working pressure of the ram type preventer, except that, where the pressure at the casing shoe would exceed 67 percent of the casing burst pressure, the casing shall be excluded from the test by using a casing hanger plug; and
- (d) each annular preventer, prior to drilling the cement out of the intermediate and production casing, to a pressure equivalent to one-half its working pressure.

4.5.21.1. Suspension of Operations - Test Results

The operator shall not proceed with any operation at a well until the tests required in section 4.5.21 have been satisfactorily completed and all BOP equipment is functioning properly.

4.5.22. Casing Wear

Casing exposed to drill pipe wear shall be tested to determine its adequacy for pressure control by either:

- (a) running a casing inspection log to determine casing wear; or
- (b) pressure testing to a pressure not greater than 50 per cent of the burst pressure of the weakest section of the casing, or to the working pressure of the blowout preventers, whichever is lesser.

4.5.23. Mechanical BOP Testing

The operator of a well shall ensure that:

- (a) the blowout prevention equipment is mechanically tested daily and any equipment found defective shall be made serviceable before operations are resumed;

- (b) for any annular type blowout preventer, all mechanical and pressure tests required by this section shall be conducted with pipe in the hole; and
- (c) all tests are to be reported in the drilling log book, and in the case of a pressure test, the report shall show the blowout preventer tested, the test duration and the test pressures observed at the start and finish of each test.

4.5.24. BOP Servicing

Blowout preventers shall be shop serviced and shop tested to their working pressure every three years and the test data and maintenance performed shall be recorded and kept by the operator.

4.5.25. Rig Crew Training

The operator of a well shall at all times ensure that:

- (a) the rig crew is trained in the operation of the blowout prevention equipment;
- (b) the driller has a First Line Supervisor certificate issued within the previous three years by the Petroleum Industry Training Service or equivalent in blowout prevention and kick control procedures;
- (c) at least one person who has a Second Line Supervisor certificate issued within the previous two years by the Petroleum Industry Training Service in well control procedures is readily available;
- (d) blowout prevention drills are performed prior to drilling out the first control casing string casing shoe;
- (e) blowout prevention drills are performed by each drilling crew every seven days;
- (f) drills performed in accordance with clauses (d) and (e) are recorded in the drilling log book; and
- (g) the procedures, calculations, formulae and current data needed to control a kick at a well are clearly posted at the rig.

4.5.26. Drill Stem Testing

When a drill stem test is conducted on a well, the operator shall ensure that there is:

- (a) a device installed above the down-hole test equipment to allow circulation of fluids through the drill string; and
- (b) a remote controlled master valve installed on the testing head.

4.6. Servicing Blowout Prevention

The operator of a well during completion, workover, re-entry, plugging, plugging-back, servicing or reconditioning, except solution mining wells where there is no pressure in the salt cavern or gallery, shall ensure that:

- (a) the well is under control;
- (b) blowout prevention equipment is installed and maintained to enable the shut off of any flow from the well regardless of the type or diameter of tools or equipment in the well;
- (c) the blowout prevention equipment installed is in accordance with the well classification and specifications set out in section 4.6.3;
- (d) the blowout prevention equipment has a pressure rating equal to or greater than the pressure rating of the production casing flange, or the formation pressure, whichever is the lesser;
- (e) hydraulic ram type blowout preventers which are not equipped with an automatic ram locking device, have hand wheels either installed or readily accessible for installation; and
- (f) for hydrocarbon salt cavern storage wells, the requirements of Class II servicing blowout prevention requirements are met.

4.6.1. Flowing Class I Gas Wells

Notwithstanding section 4.6, clause (a), gas wells in Class I may be completed, serviced or reconditioned while the well is flowing.

4.6.2. Lubricator

A full lubricator system may be used in place of or in conjunction with blowout prevention equipment specified in this Part when performing well servicing operations that are normally conducted through the wellhead assembly such as perforating, logging or stimulating wells.

4.6.3. Servicing Well Classes

For the purpose of the servicing blowout prevention requirements and the blowout prevention equipment required in Schedule 2, wells are classified as set out below:

Oil, Gas and Salt Resources of Ontario, Provincial Operating Standards

- (a) Class I: a well in which the reservoir pressure of the zone is less than 5500 kilopascals, and there is no hydrogen sulphide present in the representative sample of the gas and the well is;
 - (i) a gas well, or
 - (ii) included in a waterflood scheme;
- (b) Class II: a well where the pressure rating of the production casing flange is less than or equal to 21,000 kilopascals and the hydrogen sulphide content in a representative sample of the gas is less than 10 moles per kilomole;
- (c) Class III: a well where the pressure rating of the production casing flange is;
 - (i) greater than 21,000 kilopascals, or
 - (ii) less than or equal to 21,000 kilopascals and the hydrogen sulphide content in a representative sample of the gas is 10 moles per kilomole or greater.

4.6.4. Hydraulic Operation

All blowout preventers shall be hydraulically operated and connected to an accumulator system that shall be:

- (a) installed and operated in accordance with the manufacturer's specifications;
- (b) connected to the blowout preventers with lines of working pressure equal to the working pressure of the system and within 7 metres of the well the lines shall be of steel construction unless completely sheathed with adequate fire resistant sleeving;
- (c) capable of providing, without recharging, fluid of sufficient volume and pressure to effect full closure of all preventers, and to retain a minimum pressure of 8400 kilopascals on the accumulator system;
- (d) recharged by a pressure controlled pump capable of recovering within five minutes the accumulator pressure drop resulting from full closure of all preventers;
- (e) capable of closing any ram type preventer within 30 seconds;
- (f) capable of closing the annular preventer within 60 seconds;
- (g) equipped with readily accessible fittings and gauge to determine the pre-charge pressure; and

- (h) equipped with a check valve between the accumulator recharge pump and the accumulator.

4.6.5. Accumulator System

The accumulator system shall be connected to a nitrogen supply capable of closing all of the blowout preventers installed on the well.

4.6.6. Nitrogen Supply

The nitrogen supply shall:

- (a) be capable of providing sufficient volume and pressure to effect full closure of all preventers, and to retain a minimum pressure of 8400 kilopascals, and
- (b) have a gauge installed or readily available for installation, to determine the pressure of each nitrogen container.

4.6.7. Class I and II BOP System

For wells in Classes I and II the blowout prevention system:

- (a) may utilize the rig hydraulic system to recharge the accumulator; and
- (b) shall have operating controls for each preventer in a readily accessible location near the operator's position, and an additional set of controls located at a distance from the well of not less than 5 metres.

4.6.8. Class III BOP System

For wells in **Class III** the blowout prevention system shall have:

- (a) an independent accumulator system with operating controls for each preventer located at least 25 meters from the well, shielded or housed to protect the operator from flow from the well; and
- (b) an additional set of controls in a readily accessible location near the operator's position.

4.6.8.1. Class I BOP System

For gas wells in Class I the blowout prevention system shall have:

- (a) a diverter system consisting of two 50 millimetre nominal diameter lines, or one 75 millimetre line, connected to a valved spool below the blowout preventers, extending at least 20 metres from the well and securely tied down;

- (b) a shut-off device installed in the bottom joint of tubing to prevent flow when tripping the tubing into or out of the well; and
- (c) a tubing stripper.

4.6.8.2. Class II and III BOP Lines

For wells in Class II and III the blowout prevention system shall have two lines, one for bleeding off pressure and one for killing the well, which shall:

- (a) be either steel, or flexible hose;
- (b) be valved and having a working pressure equal to or greater than that required for the blowout prevention equipment described in section 4.6.3(c);
- (c) have one line connected to the rig pump and one line connected to the tank;
- (d) be fitted with the necessary equipment to allow one line to be connected to the tubing and a second line to be connected to the well annulus using:
 - (i) a flanged outlet on the blowout preventer below the lowest set of rams, or
 - (ii) an outlet on a spool located below the blowout preventers;
- (e) be at least 50 millimetres nominal diameter; and
- (f) be securely tied down.

4.6.9. Class II and III BOP Manifold

The blowout prevention system for wells in Class II and III shall include a manifold which shall:

- (a) consist of an arrangement of valves and steel lines which have a working pressure equal to that of the blowout prevention system specified in Schedule 2 for the applicable class of well;
- (b) contain a check valve to prevent flow from the well to the rig pump;
- (c) contain a pressure relief valve upstream of the check valve; and
- (d) be equipped with an accurate pressure gauge, which shall be either installed or readily accessible for installation.

4.6.10. Pressure Gauge

An accurate pressure gauge to determine the well annulus pressure during a well shut-in shall be either installed or readily accessible for installation.

4.6.11. Safety Valve (Stabbing Valve)

The operator shall maintain on the service rig in a readily accessible location a full opening safety valve in the open position which can be attached to the tubing or other pipe in the well.

4.6.12. Pressure Test

Before commencing operations at a well, except for a well in Class I, the operator shall ensure that a 10-minute pressure test is conducted on:

- (a) each ram preventer to 1400 kilopascals, prior to the tests described in (b) and (c);
- (b) each ram preventer, the full opening safety valve and the connection between the stack and the wellhead to the wellhead pressure rating or the formation pressure, whichever is less, and
- (c) each annular preventer to 7000 kilopascals or the formation pressure, whichever is less.

4.6.13. Annular Preventer Tests

For an annular type blowout preventer, all mechanical and pressure tests required by this section shall be conducted with pipe in the hole.

4.6.14. BOP Mechanical Tests

The operator of a well shall ensure that the blowout prevention equipment is mechanically tested daily and any equipment found defective shall be made serviceable before operations are resumed.

4.6.15. Test Recording

All tests shall be reported in the servicing log book, and in the case of a pressure test the report shall state the blowout preventer tested, the test duration and the test pressure.

4.6.16. BOP Servicing

At least once every three years all blowout preventers shall be shop serviced and shop tested to their working pressure and the test data and the maintenance performed shall be recorded and kept by the operator.

4.6.17. Training

At all times the operator of the well shall ensure that:

- (a) a driller who is the holder of a valid certificate issued by the Petroleum Industry Training Service in well service blowout prevention and well control procedures is on the well site at any time operations are in progress;
- (b) the rig crew is trained in the operation of the blowout prevention equipment;
- (c) blowout prevention drills are performed by each rig crew every seven calendar days; and
- (d) drills are performed in accordance with clause (c) are recorded in the servicing logbook.

4.6.18. Cold Weather

During cold weather operations sufficient heat shall be provided to maintain the effectiveness of the blowout prevention system.

4.7. Equipment Setback Requirements

The location of equipment used at the well site shall be spaced in accordance with the distances specified in Figure 2 and Part 5.

Part 5. Works

The following section applies to all well heads, battery sites, tank facilities, gathering lines, piping systems and processing or treatment facilities. For solution mining and the hydrocarbon storage facilities, this section applies to the point from the well head to the automatic emergency shutdown valves for hydrocarbon storage caverns and to the first isolation valves for the salt solution mining operations.

Where other publications are referenced within this Part, the reference shall be read as a reference to the most current edition of the publication in effect, including all published amendments.

5.01. Exceptions

The requirements of sections 5.14, 5.14.1, 5.15.6 do not apply to operators of private wells.

5.1. General Requirements

The operator shall:

- (a) maintain all work sites in an orderly manner;
- (b) ensure all chemicals, fuel and other substances used are safely stored; and
- (c) ensure that all waste, unused equipment is removed and disposed of properly.

5.1.1. Waste Handling

The operator of a work shall ensure that:

- (a) oil field fluid produced from a well is disposed of:
 - (i) in a disposal well licensed by the Ministry of Natural Resources and Forestry,
 - (ii) re-injected into a permitted secondary recovery project; or
 - (iii) placed in a MECP approved waste disposal facility, or otherwise handled and disposed of in accordance with the Environmental Protection Act;
- (b) the handling, storage or disposal of oil field fluid, oil, gas, refuse or any chemical or flammable products or other products or wastes used or

produced in conjunction with a well or work shall be conducted in a manner that will not:

- (i) interfere with the rights of any person,
 - (ii) create or constitute a hazard to public health or safety,
 - (iii) run into or contaminate any fresh water horizon or body of water or remain in a place from which it might contaminate any fresh water or body of water; or
 - (iv) run over or damage any land, road, building or structure;
- (c) all rubbish, debris and refuse from a well or work or resulting from any operation at a well or work is removed immediately from buildings, tanks, wells, pump stations or other sources of ignitable vapours and disposed of in such a manner that no fire hazard is created and in accordance with the Environmental Protection Act; and
- (d) stimulation fluids recovered from a well are kept separate from oil field fluid and are disposed in accordance with the Environmental Protection Act.

5.2. Well Identification – Onshore

The operator of a well shall mark the well with a prominent sign located in a conspicuous place showing the licence number of the well.

5.3. Battery and Production Facilities Identification – Onshore

The operator of a battery or production facility or work located onshore shall mark it with a prominent sign located in a conspicuous place showing the:

- (a) name of the operator; and
- (b) the phone number to call in case of an emergency at the site (emergency phone number).

5.4. Oil and Gas Waste

The operator of a well shall:

- (a) use every possible precaution to prevent the waste of oil and gas in daily operations and shall not use oil or gas wastefully or allow it to leak or escape from natural reservoirs, wells, tanks, pipes, or other work;
- (b) not vent gas to the atmosphere if the volume of gas can support a flare; and
- (c) produce solution gas in accordance with Part 6.

5.5. Setback Requirements

The operator shall ensure that all works meet or exceed the setback requirements set out in this Standard.

5.5.1. Flares

Flare pits and ends of flare lines shall not be located closer than:

- (a) 75 metres from a residential, agricultural, commercial or industrial building, school, church or place of public assembly;
- (b) 50 meters from a major pipeline, high voltage electrical transmission lines, railway, aircraft runway;
- (c) 30 metres from a wellhead, oil and brine storage tanks, pressurized storage tank, municipal road allowance, service buildings and offices; and
- (d) 15 metres from compressors, aerial coolers, other flare stacks, fired heaters, oil and brine loading docks, process towers or vessels, pumps, electrical substations or switch gear.

5.5.2. Oil and Brine Tanks

Oil and brine storage tanks shall not be located closer than:

- (a) 75 metres from any residential, agricultural, commercial or industrial building, school, church, or place of public assembly, aircraft runway;
- (b) 30 metres from a major pipeline, electrical transmission line, flare stack, flare/burn pit, office, electrical substation or switch gear;
- (c) 20 meters from any wellhead, municipal road allowance or railway;

- (d) 15 metres from compressors, service buildings, aerial coolers, furnaces, fired heaters, process vessels, treaters, pressurized storage vessels; and
- (e) 1 metre from other oil and brine tanks.

5.5.3. Process Vessels

Process vessels shall not be located closer than:

- (a) 60 metres from any residential, agricultural, commercial or industrial building, school, church or place of public assembly, aircraft runway;
- (b) 20 metres from municipal road allowance or railway;
- (c) 15 metres from an oil or brine storage tank, flare or burn pit, wellhead, office, service building and flare stack;
- (d) 10 metres from any other flame arrested, fired process vessel; and
- (e) 7 metres from an oil or brine tank where the process vessel is unfired.

5.5.4. Diesel Engines

Diesel engines shall be equipped with:

- (a) adequate air intake shut-off valves;
- (b) a system for injecting an inert gas into the engine's cylinders;
- (c) a suitable duct so that air for the engine is obtained at least 5 metres from the well; or
- (d) another approved device.

5.5.4.1. Other Engines

Internal combustion engines without air intake shut-off valves must obtain air at least 15 metres from the well.

5.5.4.2. Engine Exhaust Pipes

Engine exhaust pipes located within 15 metres of any well process vessel, oil storage tank or other source of ignitable vapour shall be so constructed that:

- (a) any emergence of flame along its length or at its end is prevented, and
- (b) the end is not closer than 2 metres to the vertical centerline of the well projected upward and is directed away from the well.

5.6. Fluid Storage

Oil and oil field fluid produced during production operations shall:

- (a) be stored in containers that are designed, constructed and operated in a safe and environmentally acceptable manner; and
- (b) shall not be stored in earthen pits or ponds or underground tanks.

5.6.1. Dikes

Oil and oil field fluid storage tanks containing oil or any fluid other than fresh water shall:

- (a) be surrounded by a dike or firewall of a capacity equal to or greater than 110 percent of the total tank capacity located within the dike;
- (b) have floors and walls constructed and maintained to have a permeability of not greater than 1×10^{-6} cm/sec measured over 72 hours with respect to the fluid being stored; and
- (c) the dike or firewall shall be maintained in good condition and the dike and the area encompassed by the dike shall be kept free from grass, weeds or other combustible materials.

5.6.2. Atmospheric Storage Tanks

Above ground storage tanks shall be used to store oil and brine and shall be designed, constructed, installed and maintained in accordance with following standards and specifications:

- (a) API Std 650, Welded Tanks for Oil Storage
- (b) API Spec 12B, Specification for Bolted Tanks for Storage of Production Liquids
- (c) API Spec 12D, Specification for Field Welded Tanks for Storage of Production Liquids
- (d) API Spec 12F, Specification for Shop Welded Tanks for Storage of Production Liquids
- (e) API Spec 12P, Specification for Fiberglass Reinforced Plastic Tanks
- (f) API Std 12R1, Installation, Operation, Maintenance, Inspection, and Repair of Tanks in Production Service
- (g) API Std 653, Tank Inspection, Repair, Alteration, and Reconstruction, for tanks fabricated to API Std 650, Welded Tanks for Oil Storage.

5.6.3. Non Spec API Tanks

Despite section 5.6.2, above ground storage tanks that are not part of a group or battery of tanks and that are less than 14 m³ (90 barrels) in nominal capacity, may be non-API specification tanks, provided that these are designed, installed and maintained for the fluids being stored.

5.6.4. Electrical Grounding

The operator shall ensure that:

- (a) above ground storage tanks are electrically grounded; and
- (b) tanker trucks and storage tanks are grounded to a common ground during loading or unloading of the tanks.

5.6.5. Cathodic Protection

Where above ground storage tanks are cathodically protected the operator shall follow the requirements of **API RP 651, Cathodic Protection of Aboveground Petroleum Storage Tanks**.

5.6.6. Storage Tank Identification

Storage tanks shall have a nameplate attached that indicates the:

- (a) applicable construction standard;
- (b) the year built;
- (c) nominal capacity;
- (d) fabricator; and
- (e) nominal diameter and height.

5.7. Piping Systems

Pipeline gathering lines shall be in accordance with **CSA Z662, Oil and Gas Pipeline Systems**. Process lines shall be in accordance with **CSA B51, Boiler, Pressure Vessel, and Pressure Piping Code**.

5.7.1. Pipeline Materials

Material used in the fabrication and installation of oil and gas pipeline systems shall meet the requirements **CSA Z662, Oil and Gas Pipeline Systems**.

5.7.2. Pipeline Construction Supervision

Where a pipeline to be used by an operator is installed, tested or replaced, the operator shall ensure that an Examiner who holds a certificate as a gas pipeline inspector or is a professional engineer licensed in the Province of Ontario certifies that the installation, testing or replacement of the pipeline has been made in accordance with this Part.

5.7.3. Burial Depth

Onshore gathering lines located outside well and battery sites shall be buried in accordance with **CSA Z662, Oil and Gas Pipeline Systems**.

5.8. Pressure Vessels

Pressure vessels used in oil and gas facilities shall be designed, constructed, installed, inspected and repaired in accordance with **CSA B51, Boiler, Pressure Vessel, and Pressure Piping Code**.

5.9. Well Flare Stacks

Individual well flare stacks and systems shall be:

- (a) 7.6 metres in height and have a nominal diameter of 60 mm for wells producing up to $1.5 \times 10^3 \text{m}^3$ per day gas to the flare;
- (b) 10 metres in height and have a nominal diameter of 60 mm for wells producing between $1.5 \times 10^3 \text{m}^3$ and $70 \times 10^3 \text{m}^3$ per day gas to the flare; and
- (c) designed, installed and operated in accordance **API Std 521, Pressure-relieving and Depressuring Systems** for wells producing in excess of $70 \times 10^3 \text{m}^3$ per day gas to the flare.

5.10. Compressor/Processing Facilities

Flare stacks and systems located at compressor stations or gas processing facilities shall be designed, installed and operated in accordance with **API Std 521, Pressure-relieving and Depressuring Systems**.

5.10.1. Gas Compressors

Where natural gas compressors are installed for use in gathering natural gas from wells or moving gas into a pipeline network for sale or consumption, the operator shall:

- (a) comply with CSA Z662, Oil and Gas Pipeline Systems, ASME B31.1 Power Piping and the Ontario Electrical Safety Code when designing, constructing, operating and maintaining the facility;
- (b) ensure that automatic shutdown controls are installed and operating correctly; and
- (c) shut down controls shall be triggered on low and high pressure.

5.11. Electrical and Area Classification

Electrical materials shall meet the requirements of:

- (a) Ontario Electrical Safety Code;
- (b) Canadian Standards Association;
- (c) API RP 500, Recommended Practice for Classification of Locations for Electrical Installations at Petroleum Facilities Classified as Class I, Division I and Division 2; and
- (d) For offshore facilities, Transport Canada TP 127 E, Ships Electrical Standards.

5.11.1. Electrical Installation

The installation of electrical equipment shall be completed by a qualified electrician licensed by the provincial authority.

5.12. Control, Limiting and Relieving of Pressure

Pressure control, limiting and relieving equipment requirements shall be in accordance with CSA Z662, Oil and Gas Pipeline Systems and CSA B51, Boiler, Pressure Vessel, and Pressure Piping Code.

5.13. Fires, Explosives

The operator of a well or work shall ensure:

- (a) that fires used for any purpose are safeguarded by sufficient mechanical or other means so as not to create a hazard to surrounding property; and
- (b) explosives or explosive materials are stored 150 metres from any production related work.

5.14. Periodic Examinations

The operator shall provide for an Examiner to visually examine all works located on land weekly, excepting wells suspended in accordance with section 5.15, for:

- (a) leaks or spills;
- (b) damage; and
- (c) any unsafe condition.

5.14.1. Annual Examination

The operator shall provide for an Examiner to examine all surface works located on land once every 12 months and to certify these works meet the Provincial Standards.

5.15. Suspended Wells

Prior to suspending a well located onshore, the operator shall:

- (a) isolate all porous and permeable zones from one another, and
- (b) ensure that all fresh water bearing zones are isolated and protected by cemented casing.

5.15.1. Isolation Method

Isolation of porous and permeable fluid bearing (including oil and gas) zones shall be accomplished by:

- (a) a bridge plug capped with cement or hydromite;
- (b) a bridge capped with stone and cement; or
- (c) other technique that positively separates the porous zones from each other in the main hole; and

- (d) if the well is to be suspended with production casing set and cemented, cementing procedures and design annular cement heights shall meet the requirements of Part 3.

5.15.2. Surface Equipment

A suspended well located onshore shall have:

- (a) two bull-plugged valves in parallel left as access to each potential source of pressure or flow of water;
- (b) if production casing has been set and cemented and if sufficient cement was not pumped during the primary cement job to isolate all main hole porous zones from the surface, a casing head or spool with at least two-valved and bull plugged side outlets to pack off the production casing/intermediate casing annulus shall be installed;
- (c) if flows of water are possible from outside the intermediate casing(s), a means of isolating the intermediate casing annulus must be installed or the flow of water must be isolated prior to suspending the well;
- (d) if potential water flow is to be isolated with a wellhead at surface, a two-valved and bull plugged access, to the annulus shall be available; and
- (e) the wellhead shall be protected with steel posts, fencing or equivalent devices.

5.15.3. Security

The operator of a suspended well located onshore and that is capable of flow shall:

- (a) remove valve handles or install a lock and chain on the main valve handles;
or
- (b) enclose the well site with a locked building or 1.5 meter chain-link fence with a locked gate.

5.15.4. Valve Function Test

The operator of a suspended well shall inspect the wellhead and valves for leaks each year.

Note: Two valves in series on the main hole or production casing are a safety precaution in case the stem, ball, or gate seizes on the outside valve. Bull plugs on

the downstream side of valves minimize the likelihood of seizing of valves by corrosion plus serves as a deterrent to gaining access to the well.

5.15.5. Valve Maintenance

The operator shall lubricate and service wellhead valves annually or more frequently if specified by the manufacturer.

5.15.6. Examination

The operator of a suspended well located on land shall:

- (a) provide for an Examiner to certify that the well has been suspended in accordance with this Standard; and
- (b) on an annual basis examine all other outlets from the well for pressures and flowing fluid, other leaks, general appearance and security of the well and to certify the continuing safety and integrity of the suspended well.

5.16. Site Rehabilitation and Works Decommissioning

Site rehabilitation shall be conducted in a manner that returns the site to near its original condition or as near to its original condition as practical no later than one year after the operations have been terminated. Rehabilitation shall include:

- (a) disposing of all liquid and solid waste in environmentally acceptable and safe manner;
- (b) clearing the area of all debris;
- (c) draining and filling the excavations;
- (d) removing all surface works, unused concrete bases, machinery, and materials;
- (e) leveling and restoring original grade of the site; and
- (f) provide for an Examiner to visit the site and certify that rehabilitation of the site was completed in accordance with this Standard.

5.17. Water Covered Areas

The operator of a producing well shall ensure that:

- (a) the wellhead is encased below the bed of the body of water; or
- (b) the over-all height of the wellhead assembly above the bed of the body of water does not exceed 1.5 meters.

5.17.1. Designated Fishing Areas

Where the area in which the well is located is designated by the Minister:

- (a) as a primary trawling area, the wellhead shall be placed in a caisson below the bed of the lake or fitted with a trawl deflector of a design approved by the Ministry, or;
- (b) for other types of commercial fishing, the wellhead shall be fitted with a protective device of a design approved by the Ministry.

5.17.2. Equipment Removal

At the end of every drilling or plugging operation, the operator of the well shall ensure that any platform, piling, anchor-post or other obstruction is removed as soon as is reasonably possible, and in any case within thirty days.

5.17.3. Permanent Platforms

Temporary or permanent production platforms shall not be used unless written approval of the platform's design and operations is granted by the Ministry.

5.17.4. Well and Pipeline Junction Identification

The operator of well or pipeline producing from a water covered area shall:

- (a) mark each well and pipeline junction with a prominent marker of a design approved by the Ministry;
- (b) identify each marker with the operator name, the well or pipeline junction designation; and
- (c) maintain such markers.

5.17.5. Offshore Pipelines

Offshore pipeline gathering systems shall be designed, constructed and maintained in accordance **CSA Z662, Oil and Gas Pipeline Systems**.

Part 6. Production

This part applies only to the production of oil and gas.

6.01 Exceptions

The requirements of sections 6.1, 6.4.1, 6.5, 6.12 and 6.12.1 do not apply to operators of private wells.

6.1. Measurement

Before production of oil and gas from a well commences, the operator shall arrange surface equipment and install metering equipment or meter test points on each well so as to permit the:

- (a) measurement of the tubing and casing pressure;
- (b) measurement of the flow rate; and
- (c) sampling of oil, gas and water.

6.1.1. Periodic Test Measurements

An operator may determine well production volumes based on periodic well test determinations and circumstances that are acceptable to the Ministry.

6.2. Records

The operator of a producing oil or gas well shall keep at an office in Ontario complete and accurate records of the well showing:

- (a) the quantities of oil, gas and water produced;
- (b) the average separator pressure, if a separator is in use;
- (c) full particulars of the disposition of all products of the well; and
- (d) where the product is sold, the name of the purchaser and amount realized from the sale.

6.2.1. Group Production

The operator may commingle oil, gas and water production from two or more wells prior to measurement where:

- (a) production from a pool averages less than 1 m³/d oil per well and 0.3 10³m³/d gas per well and all the oil gas interests subject to the commingling have been unitized;
- (b) where production recovered at surface originates from multiple deviated, horizontal or lateral wells drilled from the well at surface and all the oil and gas interests affected by the commingling have been unitized, and
- (c) production occurs from gas wells located in Lake Erie.

6.3. Conservation

The operator of a well shall use every possible precaution to prevent waste of oil or gas in production operations and in storing or piping oil or gas, and shall not use oil or gas wastefully or allow it to leak or escape from natural reservoirs, wells, tanks, containers, pipes or other works. Operators shall:

- (a) prevent the waste of hydrocarbon resources;
- (b) prevent the waste of reservoir energy;
- (c) maximize the ultimate recovery of oil and gas; and
- (d) minimize the flaring or venting of gas where practical.

6.3.1. Conservation Methods

Acceptable methods of gas conservation include:

- (a) use as fuel gas;
- (b) conversion and sale, as usable heat or electrical energy; or
- (c) re-injection of the gas into the producing formation to enhance recovery and to maintain reservoir pressure.

Note: A permit to inject under section 11 of the Oil, Gas and Salt Resources Act is required for re-injection of gas into a reservoir.

6.4. Reservoir Information

The operator shall obtain sufficient, reliable reservoir information to optimize production and to evaluate conservation options and the impact of production on the reservoir.

6.4.1. Production Records

Accurate monthly records of all oil, gas and water production volumes and reservoir pressure and fluids injected shall be made for each well. Where grouped production is allowed, accurate monthly records of the combined oil, gas and water production volumes shall be made for the subject pool or field.

6.5. Meters

For individual well metering, operators shall use positive displacement, turbine meters or tank gauging for fluid measurements and orifice, positive displacement or turbine meters for gas production measurements. Where group production occurs, the operator may use tank gauging for fluid measurement of fluid production.

Note: see section 13.11 for annual production reporting requirements.

6.6. Meter Accuracy

Where oil, gas and water production meters are installed, the operator shall ensure:

- (a) a meter accuracy of $\pm 2\%$, and;
- (b) that meters are re-calibrated and serviced when necessary, and not less than the period recommended by the manufacturer.

6.7. Reservoir Pressures

The operator shall determine the bottom hole reservoir pressure as soon as practical after drilling is complete and communication is established with the reservoir and before significant reservoir production and shall report the measurement to the Ministry on Form 7.

Note: Normally this will be after flowback on stimulation or completion of the well.

6.8. Bottom-hole Pressure Measurements

The operator shall determine bottom-hole pressure using:

- (a) static gradients with bottom hole pressure gauges run to the mid-point of the producing formation after sufficient shut-in time to attain stabilization;

- (b) shut-in and build-up tests with bottom hole pressure gauges;
- (c) electronic or mechanical recorders in the drill stem test string; or
- (d) surface deadweight pressure measurements with or without sonic fluid shots depending on the presence of fluid in the well, to calculate a stabilized bottom hole pressure.

6.9. Reservoir Fluid Samples

The operator shall:

- (a) take one representative pressurized oil and solution gas sample from each new oil pool and conduct fluid recombination and pressure-volume-temperature (PVT) studies; or
- (b) where reservoir pressure is low and solution gas production volume is low or a high draw down is necessary for significant fluid production, an oil and solution gas sample shall be collected under atmospheric conditions and accepted industry correlations shall be used to estimate PVT properties.

6.10. Initial Production Testing Period (IPTP) Report

The IPTP for exploratory and development wells shall be 120 and 90 days respectively from the well's TD date and the operator shall prepare a report that includes:

- (a) daily production volumes of oil, gas and brine;
- (b) an estimate of the well's potential oil and gas reserves and a production forecast for the well;
- (c) plans for gas conservation or alternatives being considered;
- (d) reservoir evaluation, reserve estimate, pool boundary; and
- (e) the stabilized bottom hole pressure at the beginning and end of the IPTP and the method used to determine the bottom hole pressure.

6.11. Gas Flaring

The operator of a well shall install flaring equipment and flare all gas volumes that are not conserved and that are capable of sustaining a flare.

6.11.1. Individual Wells

After the IPTP, operators shall restrict flaring to no more than a monthly volume of $45 \text{ } 10^3\text{m}^3$ or $1.5 \text{ } 10^3\text{m}^3/\text{d}$ (53 mcf/d).

6.11.2. Flared Gas Volume

The volume of gas flared shall be measured or determined as the measured produced gas volume minus the measured volume of gas sold minus any volume utilized as fuel or re-injected into the formation.

6.11.3. Daily Production

The operator shall attempt to produce the well evenly throughout the month and adhere to the daily maximum allowed volume ($1.5 \text{ } 10^3\text{m}^3/\text{d}$) of flared gas as much as practical.

6.11.4. Pools

Where two or more wells are producing from the same pool, the operator(s) shall restrict flared gas volumes to no more than $180 \text{ } 10^3\text{m}^3/\text{month}$ to be shared proportionately between operators on a well count basis. No single well shall flare more than the $45 \text{ } 10^3\text{m}^3/\text{month}$ limit.

Note: The Ministry shall have the final judgement on which wells are included in a pool.

6.11.5. Flaring Limits

Where an operator can demonstrate that conservation of gas is not feasible, operators may request a departure from flaring limits set out in this Standard. Such requests shall be submitted to the Ministry with the following information:

- (a) production forecasts of gas, oil and water from the pool under flare restrictions;
- (b) production forecasts of gas, oil and water from the pool with proposed flaring volumes in effect;
- (c) bottom hole pressure history;
- (d) a review of available gas markets in the area; and
- (e) an economic evaluation of gas conservation through sale and/or re-injection or other option(s) that demonstrates conservation is not feasible.

6.12. Gas Measurements

The operator of a gas pool located onshore shall:

- (a) take an annual shut-in pressure measurement on each well in the pool; or
- (b) where well pressures can be shown to be representative of the reservoir pressure, take annual shut-in pressure measurements only on the representative wells; and report the measurements made in (a) or (b) on Form 8; and
- (c) where an operator has completed a gas well with an estimated open flow in excess of $28.3 \times 10^3 \text{m}^3$ per day, determine the deliverability of the well according to recognized standards of back-pressure testing and shall report the observed field data to the Ministry and report the results on Form 7.

6.12.1. Shut-in Pressure

The annual shut-in pressure measurement shall be:

- (a) taken with a dead-weight gauge or other equipment acceptable to the Ministry;
- (b) taken after sufficient shut-in time has passed for reservoir stabilization or 24 hours shut-in time whichever is the lesser; and

reported as gauge pressure on Form 8.

Part 7. Oil Field Fluid Disposal Wells

No person shall commence disposal operations without written approval from the Ministry.

Operators shall design, construct, operate and maintain oil field fluid disposal wells to:

- (a) permanently isolate and protect all potable water formations from contamination;
- (b) protect existing and potential hydrocarbon-bearing formations from contamination caused by migration of the injected fluid;
- (c) prevent the migration of fluids between permeable formations;
- (d) ensure that the disposal fluids are compatible with the disposal formation such that precipitates or clay mobilization are minimized; and
- (e) ensure that the disposal fluids are retained within the disposal formation.

Note: A typical disposal well design is shown in Figure 3.

7.01 Restricted Disposal Areas

Disposal into the Detroit River formation in areas located within 8 km of the St. Clair River is prohibited.

7.1. Notification

An operator planning to dispose of oil field fluid shall notify in writing:

- (a) all landowners and other operators located **within** 750 metres of the proposed well site;
- (b) the municipality in which the disposal well is situated; and
- (c) the Ministry

7.2. Disposal Well Design and Construction

The operator shall design and construct a disposal well to include:

- (a) injection of oil field fluid through tubing;

- (b) isolation of the annular space between the tubing and production casing from the injection zone by a packer or some other acceptable method;
- (c) placement of a corrosion inhibitor within the annulus outside the injection tubing;
- (d) isolation of all fresh water zones with casing and cement;
- (e) cementing the surface casing, intermediate and product casings to surface; and
- (f) wellhead components that are rated to 110 percent of the maximum operating pressure.

7.3. Formation Water Sampling

The operator shall collect and analyze samples of water from each aquifer penetrated during the drilling of the disposal well, and:

- (a) record the depth, chemical characteristics and static level of each aquifer; and
- (b) provide a copy of the chemical analysis of each formation water to the Ministry.

7.4. Existing Well Conversions

Conversion of existing wells for use as disposal wells may be made if:

- (a) the well's condition and construction meets the requirements of this Standard; and
- (b) for conversion of a well older than 10 years, the operator conducts additional pressure tests, casing evaluation logs and cement evaluation logs to demonstrate the integrity of the well's casing and the cement seal.

7.4.1. Old Wells

Wells that are 20 years and older shall not be converted for use as a disposal well.

Note: No departures from this requirement will be accepted.

7.5. Disposal Report

The operator shall prepare and submit a report to the Ministry on the suitability of the proposed disposal well and formation for oil field fluid disposal and the report shall include:

- (a) the name and address of the operator;
- (b) the location, identity, status, depth, formation at total depth, the oil, gas, water and loss of circulation zones encountered in wells located within 750 metres of the proposed disposal well;
- (c) for wells identified in item (b), that penetrate the disposal formation, the casing, cementing and plugging details of the wells;
- (d) the location and status of potable water wells within 750 metres of the proposed disposal well;
- (e) a description of all uses of the subsurface within 750 meters of the proposed well;
- (f) a chemical analyses of the formation water in the proposed disposal;
- (g) the chemical analyses of water samples taken from the fresh water wells or selected representative wells identified in item (d);
- (h) the initial reservoir pressure of the disposal zone;
- (i) the volume, rate, and maximum injection pressure for the proposed disposal operation;
- (j) the source, chemical composition and specific gravity of injected oil field fluid;
- (k) results of fluid compatibility tests of the proposed disposal fluid with the formation water located in the disposal zone;
- (l) the projected subsurface area of influence of the fluid disposal operation over time;
- (m) the geology of the disposal formation, its lateral extent, the nature of the upper and lower confining beds, its reservoir characteristics, and its oil and gas potential;
- (n) the results of the injectivity test;
- (o) the drilling and completion record including any stimulation and workover of the well;

- (p) a complete description of the installation and cementing of the surface, intermediate and production casings;
- (q) a complete report on the installation of the injection tubing;
- (r) records of the tests of the integrity of the various casings;
- (s) the well history, if a conversion of an existing well;
- (t) a detailed record and cross-sectional diagram of the method of well completion (well-bore diagram);
- (u) a description of the proposed fluid handling procedures;
- (v) a site plan of the wellhead and associated facilities; and
- (w) if external pressure is necessary for the injection of oil field fluid, an assessment of the impact of the applied pressure on the disposal zone, other formations, and subsurface resources.

7.6. Disposal Operations

The operator shall:

- (a) only inject oil field fluid (formation water and drilling fluid) into a disposal well that:
 - (i) is produced by the operator, or
 - (ii) originates from the same field and is delivered by pipeline to the disposal well;
- (b) not inject fluids that are classified as "liquid industrial waste" under the Environmental Protection Act, including stimulation fluids, unless the well is licensed by the Ministry of **the Environment, Conservation and Parks** for that purpose; and
- (c) not inject oil field fluid between the outermost casing and the well bore or into the annular space between strings of casing.

7.7. Recommended Injection Practice

Oil field fluids shall be injected:

- (a) by gravity feed with no applied pressure or by the lowest practical pressure not exceeding 75% of the known fracture gradient; and
- (b) into suitable formations located as deep as practical.

7.8. Pre-Commissioning

Prior to commencing injection of oil field fluid into a disposal well, other than for the initial injectivity test, the operator shall:

- (a) identify all known wells and water wells within 750 metres of the disposal well;
- (b) confirmed the integrity of the injection casing of the disposal well by pressure tests and/or cement evaluation logs;
- (c) run a cement bond log or equivalent logs to verify the integrity of cement; and
- (d) conduct an injectivity test on the candidate disposal zone to supplement existing permeability and porosity data and to determine the quality of any candidate disposal zone;
- (e) submit the disposal report required in section 7.5; and
- (f) submit an operating procedure for the proposed disposal operations.

7.8.1. Water Wells

Prior to commencing injection of oilfield fluid, the operator shall collect water samples from selected, accessible fresh water wells located within 750 metres of the proposed disposal well and obtain chemical analyses of the samples suitable for characterization of the ground water according to the specifications of the Ministry of the Environment, Conservation and Parks and during the collection of the samples, the operator shall obtain from the water well owner the following information about each water well and submit this information to the Ministry with the chemical analyses:

- (a) depth of well;
- (b) age of well;
- (c) volume of water taken from the well; and
- (d) static level of the water in the well.

7.9. Initial Injection Test

The operator shall submit the program for the initial injectivity test of a disposal well to the Ministry prior to the commencement of the test and injection of fluids during the test shall be through tubing set on a packer located as close as practical above the injection zone.

7.9.1. Injection Test Program

The injectivity test program shall include:

- (a) the depths of the injection intervals;
- (b) the rates of injection;
- (c) injection pressure(s); and
- (d) the volume and source of the fluids to be injected.

Note: Sampling of the original formation water is required under section 7.3 and should be done prior to injection of any fluid for testing.

7.9.2. Injection Test Pressure

During the initial injectivity test, the subsurface pressure at the midpoint of the disposal zone shall not exceed 75% of the formation fracture pressure.

7.9.3. Injection Test Duration and Volume

The initial injectivity test shall not exceed:

- (a) 30 days in length; and
- (b) 500 m³ in total injected fluid.

7.10. Disposal Well Operations

The operator shall not commence disposal operations unless written approval is received from the Ministry.

7.10.1. Fluid Measurement

The operator shall measure the volume of fluid injected and the injection pressures.

7.10.2. Corrosion Blanket

The presence of corrosion inhibiting fluid and the isolation of this fluid from the injected fluid, shall be witnessed and certified by an Examiner using a pressure gauge, visual inspection or equivalent means semi-annually.

7.10.3. Maximum Injection Pressure

The subsurface pressure at the midpoint of the disposal zone shall not exceed 75% of the formation fracture pressure at that depth during the injection of oil field fluid except during well stimulation.

7.11. Site Plans

The operator shall keep and maintain plans and maps of the disposal well and associated storage and collection facilities.

7.12. Spill Contingency Plan

The operator shall have, at its operations center or office, available at all times, a spill contingency plan in the event of a leak or break in a pipeline, storage tank or wellhead and operations personnel shall be trained and knowledgeable regarding this plan.

7.13. Periodic Pressure Test

The operator shall conduct a pressure test of the annular space after every 5 years of injection and provide for an Examiner to certify the mechanical integrity of the well at this time.

7.14. Termination of Injection

Injection of fluid shall be stopped immediately after loss of fluid or an increase of pressure is detected in the tubing annulus, and shall not resume until the cause is determined and remedy is made.

7.15. Records

The operator shall keep and maintain the following information for each disposal well:

- (a) name and location of disposal wells;
- (b) monthly and cumulative volume of fluid disposed;
- (c) volume of fluid from each source;
- (d) the operating range of surface pressures during injection;

- (e) maximum surface pressure applied during injection;
- (f) name of the formation used for disposal;
- (g) the depth interval(s) used for disposal;
- (h) records of subsurface pressure measurements, pressure fall-off tests and other reservoir performance or evaluation tests;
- (i) copies of chemical analyses from fresh water wells adjacent to the disposal well;
- (j) descriptions and results of mechanical integrity tests at the well;
- (k) description of workovers, acid treatments, and fracture stimulations conducted during the year; and
- (l) the source well name and licence number, chemical characterization and transmittal slips for oil field fluids disposed of in the disposal well.

7.16. Periodic Examinations

The operator shall provide for an Examiner to examine disposal well facilities and operations semi-annually and to certify that all disposal well standards are met.

Part 8. Well Servicing

Well servicing includes any activity in or on the well including completion, workover, re-entry, plugging, plugging-back, overhaul, logging, sampling, temperature and pressure gauging, fishing, stimulating, acidizing, or perforating, etc.

8.1. BOP Requirements

The operator shall install and maintain in working condition blowout prevention equipment in accordance with Part 4 for well service operations on wells capable of flowing and when the tubing bonnet or valve is removed from the wellhead.

8.1.1. Lubricator Rating

Lubricator systems must be rated for working pressures that exceed reservoir pressures by a factor of at least 20%.

8.2. Service Equipment Setback Requirements

The operator shall ensure that service equipment is spaced in accordance with Figure 2 and that operations are shut down when wind conditions are detrimental to a safe operation.

8.3. Annular Pressure Gauge

The operator shall install or have readily available for installation an accurate pressure gauge to determine the well annulus pressure when the well is shut-in.

8.4. Internal Combustion / Diesel Engines

See Part 5, sections 5.5.4, 5.5.4.1, 5.5.4.2.

8.5. Safety Valve (Stabbing Valve)

The operator shall maintain on the service rig in a readily accessible location a full opening safety valve (stabbing valve) in the open position which can be attached to tubing or other pipe in the well.

8.6. Electric Wireline Operations

A stub lubricator system shall be used during all logging operations in place of a full lubricator on wells that have insufficient reservoir pressures to flow to surface.

8.7. Electrical Grounding

The picker, mast unit, or rig and wireline unit shall be grounded to equal the electrical potential between the flowlines, wellhead and all equipment.

8.8. Drill/Service Sump

See section 3.2.

8.9. Sump/Pit Closure

See section 3.3.

8.10. Record Keeping

The operator shall keep a record of all servicing conducted on the well.

Part 9. Solution Mining

This Part covers the design, construction, operation and abandonment aspects for salt solution mining in Ontario.

Where other publications are referenced within this Part, the reference shall be read as a reference to the most current edition of the publication in effect, including all published amendments.

9.1. Design and Construction

Salt solution mining operations shall be designed, operated and constructed to:

- (a) protect potable water and other fluid bearing zones;
- (b) ensure the structural stability of the salt bed and overlying geological formations is maintained;
- (c) protect the surface and subsurface for other potential uses;
- (d) ensure that salt solution mining is occurring in suitable formations; and
- (e) optimize the salt resource extraction without adversely impacting public safety or the environment.

9.2. New Project Development

Proposals for new salt solution mining projects shall be submitted to the Ministry with the following information:

- (a) a map showing the type and surveyed location, and depth of all wells within a 1 kilometre radius of the proposed mining property;
- (b) a table of the wells identified in (a), showing the date the well was drilled, its depth, and current status;
- (c) a geological cross-section interpreted from gamma ray and neutron density well logs and any applicable well records identifying the geologic formations between the surface and the top of the salt formation and the depths at which they occur;
- (d) the depth and formation of fresh water bearing and other formation water bearing strata likely to be encountered;
- (e) the proposed location of salt solution mining well(s);

- (f) a geological analysis of the salt formation proposed for mining, including its depth and thickness;
- (g) a subsurface schematic drawing (wellbore diagram) of each proposed well;
- (h) a schematic drawing of the proposed surface facilities including the wellheads and pipelines;
- (i) the structural stability model to be used in the development of the mining plan; and
- (j) a mining plan.

9.3. Mining Plan

The mining plan submitted in section 9.2 shall include the following:

- (a) the physical properties of the salt formation including assessment of creep and closure potential under the proposed mining plan;
- (b) the structural top and base of the salt formation including any fluid interfaces;
- (c) the mechanical behaviour of the formations above the salt formation;
- (d) the impact of impurities and other anomalies on the strength of salt formation and formations above the salt formation including an assessment of regional, local and internal faulting and their implications on the mining plan;
- (e) the potential for fluids to migrate to or from the salt solution mining zone or to or from other formations;
- (f) an assessment of the regional stresses;
- (g) the designed shape of the cavern or gallery including maximum diameter;
- (h) the proposed salt extraction rates and anticipated subsidence rates;
- (i) the designed distance between caverns and/or galleries;
- (j) the designed injection and extraction rates including flow rates, pressures, roof and shape control;
- (k) depth of extraction and the circulation method;
- (l) the maximum extraction ratios;
- (m) an assessment of the magnitude of the ground subsidence as a function of time during and after active solution mining.
- (n) subsidence monitoring program, monuments and measurement;

- (o) sonar monitoring program with specified sonar frequency;
- (p) the planned total extraction of salt from each well;
- (q) the final designed shape of the cavern around each well; and
- (r) contingency plans in case of spills and cavern collapse.

9.4. Injection Pressure

The maximum injection pressure shall not exceed 75% of the local fracture gradient.

9.5. Mining Restrictions

Salt solution mining operations shall be limited to:

- (a) property that is owned or under mineral lease to the operator;
- (b) wells located at least 150 metres from the operator's property or lease boundaries;
- (c) salt extraction that is not closer than 50 metres from the operator's property or lease boundary lines.

9.5.1. Hydraulic Control

All caverns and galleries shall have tight hydraulic control during the salt solution mining operations.

9.6. Roof Control

The operator shall employ a blanketing material continuously throughout the solution mining process for roof control.

9.7. Drilling

All solution mining wells shall be drilled and completed in accordance with Part 3 with the following exceptions:

- (a) surface, intermediate and production casings shall be cemented to surface as shown on Figure 4;
- (b) the production casing shall be set at least 3 metres into the producing salt formation;

- (c) the mechanical integrity testing procedure shall be conducted prior to commencing solution mining operations and shall include:
 - (i) a cement bond log (or equivalent) and a casing evaluation log on the production casing,
 - (ii) a pressure test on the production casing and seat, and
 - (iii) a pressure test of the formation immediately below the production casing seat; and
- (d) the hanging tubing string(s) shall be in accordance with **API Spec 5CT, Specification for Casing and Tubing.**

9.8. Mining Operations

Salt solution mining and salt production shall be carried out in accordance with the written mining plan.

9.8.1. Operation and Monitoring

The operator shall:

- (a) have a written procedures that include:
 - (i) operating and maintenance procedures,
 - (ii) emergency response procedures, and
 - (iii) procedures that specify the necessary system isolation required to perform maintenance functions, including venting and blowdown;
- (b) operate the facility in conformance with the procedures in (a);
- (c) keep records necessary to administer such procedures;
- (d) ensure that operations and maintenance personnel are trained and familiar with all procedures;
- (e) update procedures from time to time as experience dictates and as changes in operating conditions require;
- (f) limit the maximum injection and withdrawal rates to less than a velocity of 4.5 metres/second (15 ft/sec);
- (g) maintain records and documents for the:
 - (i) maintenance and operation activities on wells, pipelines and associated equipment, and

- (ii) down hole activities including copies of all logs; and
- (h) keep daily records of:
 - (i) the volume of water injected and/or brine recovered, and
 - (ii) the volume and pressure of the blanketing material and the volume of any blanketing material added or removed.

9.8.2. Mechanical Integrity Testing

The operator shall:

- (a) conduct mechanical integrity testing of the production casing once every five years by:
 - (i) a casing evaluation log;
 - (ii) a pressure test of the casing or a water brine interface test; or
 - (iii) other equivalent methods acceptable to the Ministry; and
- (b) provide for an Examiner to certify the mechanical integrity of each well.

9.8.3. Hydraulic Control Monitoring

The operator shall monitor hydraulic closure by continuous direct flow or pressure measurements and provide for an Examiner to certify hydraulic closure to the Ministry annually.

9.8.4. Sonar Surveys

The operator shall:

- (a) conduct a sonar survey through each well at every 360,000 net tonnes interval of salt production from the well;
- (b) plot the results of the sonar survey on a maximum radii plot along with other well sonar surveys on a mining property layout plan; and
- (c) use these surveys to ensure that solution mining is occurring in accordance with the mining plan.

9.8.5. Subsidence Monitoring

The operator shall:

- (a) conduct subsidence monitoring annually using a qualified surveyor; and

- (b) plot on a continuous graph the subsidence survey data and provide such data to the Ministry in a tabular format.

9.8.6. Servicing Blowout Prevention

Operators of solution mining wells shall comply with sections 8.1, 8.6 and 8.7 when conducting well service operations.

9.9. Abandonment

Solution mining well abandonment shall include:

- (a) a sonar survey on the cavern;

- (b) a mechanical test on the casing; and

plugging the well in accordance with Part 11 of this Standard with the exception that cement shall be placed over the full length of the well bore.

Part 10. Hydrocarbon Storage

Facilities for storage of hydrocarbons in underground formations shall be designed, constructed, operated, maintained and abandoned in accordance with **CSA Z341, Storage of Hydrocarbons in Underground Formations.**

Where other publications are referenced within this Part, the reference shall be read as a reference to the most current edition of the publication in effect, including all published amendments.

10.1. MIT Test Examinations

Where mechanical integrity testing is conducted on a cavern system the operator shall provide for an Examiner to examine the test results and certify their validity.

10.2. Annual Examination

The operator shall provide for an annual examination of all surface works located on land and an Examiner to certify that these works meet this Standard.

10.3. Reporting

Reporting shall be in accordance with Part 13 with the following additions:

The ministry shall be notified of:

- (a) in the case of cavern storage facilities:
 - (i) of planned well overhauls and inspections and the results of such inspections including copies of all the sonar surveys, logs, test data and the interpretations of this data;
 - (ii) when there is a change of service in a cavern from one type of product storage to another;
 - (iii) of suspected damaged to a brine stringer or hydrocarbon leaks at the well head or casings; and

in all types of storage operations, immediately when any emergencies occur, including spills, loss of well control, fire, explosion or other accident.

Part 11. Well Plugging

Where other publications are referenced within this Part, the reference shall be read as a reference to the most current edition of the publication in effect, including all published amendments.

11.01 Every person who plugs a well shall do so in a manner that:

- (a) ensures the protection of potential oil or gas producing horizons;
- (b) prevents the migration of oil, gas or water from one horizon to another;
- (c) seals off and isolates all porous formations from those located above and below; and
- (d) does not constitute a hazard to users of the surface.

Note: Refer to section 13 for well plugging reporting requirements.

11.1. Hydrocarbon Storage and Solution Mining Wells

- (a) Plugging of hydrocarbon storage wells shall be in accordance with CSA Z341, Storage of Hydrocarbons in Underground Formations.
- (b) Solution mining wells shall be plugged in accordance with the requirements of Section 9.9.

11.2. Removal of Well Casing and Equipment

Casing, tubing and foreign material shall be removed from the well sufficiently to conform to the requirements of this Part.

11.3. Plugging Materials

- (a) Cement plugs shall be:
 - (i) neat cement without the addition of volume extender additives, gravel or any non-drillable material,
 - (ii) mixed in accordance with API Spec 10A Specification for Cements and Materials for Well Cementing,

- (iii) in the form of a water-base slurry, having a weight of 1.9 kg per litre, and
 - (iv) sulphate resistant where intended to isolate sulphur-bearing fluid zones.
- (b) Bridges shall be of wood or stone, gravel, lead, or any combination of these or a special bridging device, but shall not include any non-drillable material.

11.4. Method of Plug Placement

Cement shall be deposited by displacement through tubing or drill pipe or by dump bailer.

11.5. Plug Volume

- (a) Pumped cement plugs, except the top plug, shall have sufficient slurry volume to fill 30 metres of hole plus 10% excess.
- (b) Dump-bailed plugs shall have sufficient volume to fill 8 metres of hole plus 10% excess.

11.6. Locating Plugs

The operator shall locate (tag) and provide for an Examiner to certify the placement and location of:

- (a) each plug set at the top of each oil or gas fluid bearing zone, storage zone or salt cavern roof; and
- (b) the top most plug set in the well

11.7. Plug Interval Material

The intervals between plugs shall be filled with water or drilling mud.

11.8. Location of Cement Plugs

Regardless of whether casing is cemented in the hole the operator shall set cement plugs:

- (a) above and below each oil, gas and fluid bearing zone and
- (b) at the top of the Cambrian, Trenton, Cataract, Guelph, Salina, Dundee and bedrock formations, and at the base of the Guelph formation.

11.9. Size of Plugs

Cement plugs shall extend a distance of 8 metres in the well.

11.10. Recovery of Casing

The operator shall ensure that procedures for the recovery of casing comply with the following:

- (a) surface casing, or other casing one size smaller in lieu thereof, may be recovered and where surface casing is left in the hole, it shall be fitted with a welded cap, or plugged with at least 3 metres of cement, and in all cases shall be cut off 1 metre below grade, except where the well is in a water-covered area, then the surface casing shall be cut off at or below the bed of the body of water;
- (b) where surface casing is removed, the hole shall be filled completely to the surface with clay or sand or cuttings as the surface casing is withdrawn, except that a cement plug shall be set between 1 metre and 2 metres from surface; and
- (c) when insufficient surface casing is set to protect every zone which contains potable water, and any such stratum is exposed to the well bore when production or intermediate casing is recovered from the well, a cement plug shall be placed across the interval from 15 metres below the base of the zone to 15 metres above the top of the zone.

11.11. Additional Plugs

Additional cement plugs shall be set as follows:

- (a) across the shoe of the surface casing extending at least 8 metres above and below the shoe;
- (b) if surface casing has been set deeper than 60 metres below the base of the deepest potable water zone, an additional cement plug shall be placed inside the surface casing across the base of the deepest potable water zone;
- (c) for wells in which the intermediate casing has been cemented across every porous zone intersected, a cement plug shall be placed inside the casing immediately below the base of the deepest potable water zone;

- (d) if intermediate casing is to be left in the hole, a plug must be set across the shoe extending at least 8 metres above and below the shoe;
- (e) for wells in which intermediate casing is not cemented through every porous zone, the casing shall be recovered to allow optimum placement of cement plugs;
- (f) for wells in which the production casing has been cemented through every porous zone, a cement plug shall be placed inside the casing and immediately below the base of the deepest potable water zone and across any multi-stage cementing tool;
- (g) for wells in which the production casing has not been cemented through every porous zone, the production casing shall be recovered to allow optimum placement of cement plugs at the required depths specified above;
- (h) for horizontal drain hole wells the productive zone isolation plug shall be 8 metres and set at the top of the productive zone, or across the shoe of the production casing.

11.12. Bridge Plugs

The operator may run a bridge plug above each perforated interval, if at least 8 metres of cement is placed on top of each bridge plug.

11.13. Well Site Rehabilitation – Onshore

The operator shall return the well site to its original condition as nearly as practical and as soon as practical but no later than 6 months from the plugging date and the operator shall provide for an Examiner to visit the site and certify that rehabilitation and plugging of the well was completed in accordance with this Standard.

Rehabilitation shall include:

- (a) disposing of all liquid and solid waste in environmentally acceptable and safe manner;
- (b) clearing the area of all debris;
- (c) draining and filling the excavations;
- (d) removing all surface works, unused concrete bases, machinery, and materials; and
- (e) leveling and restoring original grade of the site.

11.13.1. Well Site Rehabilitation - Water Covered Areas

When a well located in a water covered area is plugged, the operator shall cut off any casing left in the well at or below the bed of the body of water.

11.14. Reporting

The operator shall record the cement type, slurry weights, slurry volume, and special additive concentrations on the daily drilling report and submit a Form 10 report as required in Part 13 for every well plugged.

Part 12. Oil, Gas and Salt Resources Trust

Sample Processing Fees

The licensee of a well shall:

- (a) calculate the drilling sample processing fee using the appropriate rates and formula below;
- (b) make the fee payment payable to the Oil, Gas and Salt Resources Trust; and
- (c) submit the fee payment along with the Form 7 required for the well

Sample Processing Fee Schedule

Type of Samples	Rate (\$/m)
A: Bagged samples from vertical and deviated sections of wells.	\$0.90
B: Bagged samples from horizontal sections of wells.	\$0.45
C: Vialled samples from vertical and deviated sections of wells.	\$0.60
D: Vialled samples from horizontal sections of wells.	\$0.30
E: Full diameter core delivered unslabbed to the Library.	\$30.00
F: Full diameter core delivered to the Library and slabbed to Library specifications.	\$10.00

Note: Refer to section 3.18 for drill sample collection standards.

Drilling Sample Processing Fee Calculations

(i)	Metres of Type A bagged samples	X	Rate Type A = _____
(ii)	Metres of Type B bagged samples	X	Rate Type B = _____
(iii)	Metres of Type C vialled samples	X	Rate Type C = _____
(iv)	Metres of Type D vialled samples	X	Rate Type D = _____
			SUBTOTAL _____
			13% HST _____
			TOTAL \$ _____

Note: Fees for drill core samples will be invoiced to the operator.

Part 13. Reporting

The operator shall make the following reports and use SI units when entering numerical information. The most recent version of the Ministry Forms shall be used when making reports. Note: Forms may be amended from time to time. Please contact the Petroleum **Operations Section** or visit the website <http://www.ogsrlibrary.com> for the latest version.

13.1. Forms

- Form 1: Application for a Well Licence
- Form 2: Well Licence
- Form 3: Annual Well Status Report
- Form 4: Annual Report of Geophysical/Geochemical Surveys
- Form 5: Annual Report of Solution Mined Salt Production
- Form 6: Annual Report of Monthly Injection
- Form 7: Drilling and Completion Report
- Form 8: Annual Report of Monthly Oil and Gas Production
- Form 9: Annual Report of Subsurface Oil Field Fluid Disposal
- Form 10: Plugging of a Well Report
- Form 11: Application for Minister's Consent to Well Security Adjustments

13.2. Drilling Activity Notices

The operator shall notify the Ministry by **email at posrecords@ontario.ca, or by fax at 519-873-4645**, of:

- (a) the commencement of well drilling, including deepening, 48 hours prior to the start of drilling operations;
- (b) where the drilling program for a well was not completed and is not expected to resume for a period greater than 7 days, the:
 - (i) date drilling was suspended,
 - (ii) well's depth, and

- (iii) the condition of the well as left-in, including casing and cement and wellhead equipment, within 48 hours after the date drilling was suspended;
- (c) TD date, total depth of the well and the well's status within 48 hours after the TD date;
- (d) the completion date and the well's status, within 48 hours after the completion date; and
- (e) the plugging of a well, within 48 hours prior to commencing plugging operations

Notes: Section 13.2 (b) does not apply to routine rig changes included in the drilling program that result in suspension of the drilling program for periods less than 7 days.

Changes to the well application form, drilling program and well location plan must be reported to and approved by the Ministry in accordance with **Ontario** Regulation 245/97.

13.3. Emergency Notification

The operator of a work shall report to the Ministry immediately and shall report further in writing any:

- (a) well flowing uncontrolled;
- (b) spill from a work;
- (c) well blowout; and
- (d) fire or explosion involving works.

13.4. Drilling and Completion Report

Where a well is drilled or deepened the operator shall make a report in duplicate to the Ministry within sixty days after the end of drilling (TD Date), working-over, re-entry operations in Form 7 (Drilling and Completion Report).

Note: Form 7 must be accompanied by payment for all applicable sample-processing fees, see Part 12.

13.5. Drill Samples

Every operator shall, within thirty days after the end of well drilling or deepening operations (TD date), deliver to the Oil, Gas and Salt Resources Library at the operator's expense samples of drill cuttings or fluid samples collected in accordance with section 3.18.

13.5.1. Drill Sample Bags and Vials

Operators shall only use drill sample bags or vials provided by the Oil, Gas and Salt Resources Library.

13.6. Drill Core

Where drill cores are taken, the operator shall:

- (a) pack them in accurately labeled, numbered boxes showing the name of the well and licence number and the corresponding depth interval;
- (b) protect the boxes from damage; and
- (c) report the depth intervals of the core on Form 7 to the Ministry.

13.6.1. Core Analysis

Where a core analysis or any other analysis has been conducted by or for an operator, the operator shall submit two copies of the analysis to the Ministry within thirty days of completion of the analysis.

13.7. Core Maintenance

The operator shall ensure that:

- (a) no core is destroyed, except for the purposes of analysis; and
- (b) cores are delivered to the Oil, Gas and Salt Resources Library at the operator's expense within one year after the TD date of the well.

13.8. Well Logs and Surveys

Where any log or survey is taken in a well, two final copies of the log or survey shall be supplied to the Ministry by the operator within thirty days after the log or survey has been made.

13.9. Well Activities

Where a well is worked over, stimulated, tested, re-entered, plugged-back or re-cased, the operator shall make a report in duplicate to the Ministry within thirty days of completion of the work in Form 7.

13.10. Tests and Measurements

An operator shall, within thirty days of conducting a test or measurement, submit to the Ministry, in duplicate, the observed data of all tests and measurements made, including but not limited to the following:

- (a) connate water or other liquid saturation determinations;
- (b) two copies of each drill stem and production test including the chronological sequence and depth interval of each test; and
- (c) static top hole or bottom hole pressure measurements;
- (d) flowing or other special bottom hole pressure measurements and back pressure tests; and
- (e) oil, gas, water and pressure-volume-temperature (PVT) determinations, including:
 - (i) solution and evolved gas ratios,
 - (ii) liquid phase volumes,
 - (iii) formation volume factors,
 - (iv) tank oil gravities,
 - (v) separator and stock tank gas-oil ratios,
 - (vi) bubble point pressure of reservoir fluid,
 - (vii) compressibility of saturated reservoir oil,
 - (viii) viscosity of reservoir oil, and
 - (ix) fractional analysis of casing head gas and saturated reservoir fluid.

13.11. Annual Production Report

An operator shall, on or before the 15th day of February in each year, make a complete and accurate report in duplicate to the Ministry in Form 8 (Annual Report

of Monthly Well or Field/Pool Production) in respect of production occurring in the preceding calendar year.

13.12. Injection Report

The operator holding a Permit to Inject issued under section 11 of the Oil, Gas and Salt Resources Act shall, on or before the 15th day of February in each year, make a report in duplicate for all injection wells to the Ministry in Form 6 (Annual Report of Monthly Injection) in respect of the preceding calendar year.

Note: Annual shut-in pressure measurements that are required by section 6.12 are required to be reported on Form 8.

13.13. Disposal Well Reports

The operator of a well for the disposal of oil field fluid shall:

- (a) submit a report on the following within 30 days of completion of such work;
 - (i) records of subsurface pressure measurements, pressure fall-off tests and other reservoir performance tests,
 - (ii) copies of chemical analyses from fresh water wells located adjacent to the disposal well, and
 - (iii) mechanical integrity tests of the well; and
- (b) on or before the 15th day of February in each year, make a report in duplicate to the Ministry in Form 9 (Annual Subsurface Fluid Disposal Report) in respect of the preceding calendar year.

13.14. Well Plugging Report

Where a well is plugged, the operator who plugs the well shall make a report in duplicate to the Ministry within 30 days in Form 10 (Plugging of a Well Report).

13.15. Exploration Report

A person conducting geophysical or geochemical exploration for oil or gas shall, on or before the 15th day of February in each year, make a report in duplicate to the Ministry in Form 4 (Annual Report of Geophysical/Geochemical Activity) in respect of the preceding calendar year.

13.16. Annual Well Status Report

The operator of a well shall, on or before the 15th day of February in each year, for the previous calendar year, submit Form 3 showing:

- (a) all the operator's wells;
- (b) the status of each well; and
- (c) the calculation of its licence fees; and
- (d) be accompanied by its licence fees payable to the Oil, Gas and Salt Resources Trust.

13.17. Third Party Gas Reports

Any natural gas Local Distribution Company (LDC) which measures, purchases or transports natural gas from a well shall on or before the 15th day of February in each year, make a report to the Ministry in respect of the preceding calendar year and the report shall include:

- (a) operator name;
- (b) well location or meter point;
- (c) well name;
- (d) pool name; and
- (e) the cumulative year to date volume and value of natural gas measured, purchased or transported for each well location or meter point.

13.18. Third Party Oil Reports

Any person that purchases crude oil from a well shall on or before the 15th day of February in each year, make a report to the Ministry in respect of the preceding calendar year and the report shall include:

- (a) operator name;
- (b) well location or meter point;
- (c) well name;
- (d) pool name; and
- (e) the cumulative year to date volume and value of oil purchased for each well location or meter point.

13.19. Initial Production Test Period (IPTP) Report

The operator of a well completed for oil or gas production shall submit the IPTP report required by section 6.10 to the Ministry within 10 days after the end of the IPTP period.

13.20. Reporting Voluntary Units

The operator of a unit area which has been voluntarily unitized, shall report the unit area and the following information to the Petroleum **Operations Section**:

- (a) the effective date of the unit agreement;
- (b) the name of the unit operator;
- (c) a geographical and geological description of the unit area;
- (d) a plat showing the:
 - (i) boundaries of the unit area,
 - (ii) individual tracts,
 - (iii) participating area,
 - (iv) location of wells, including the legal name and licence number of each well, and
- (e) a copy of the unitization agreement between the royalty interest owners and the working interest owners.

13.21. Amendments to Units

The operator of a unit area, whether established voluntarily or by an Order of the Commissioner, which has been voluntarily amended, shall report the following information to the Petroleum **Operations Section**:

- (a) the reason for such amendment;
- (b) the effective date of the amendment;
- (c) a list of the names of the royalty interest owners and working interest owners who agreed to such amendment;
- (d) the name of the unit operator;
- (e) a geographical and geological description of the unit area, if amended;

- (f) a plat showing the amendments to the:
 - (i) boundaries of the unit area,
 - (ii) individual tracts,
 - (iii) participating area, and
 - (iv) location of all wells, including the legal name and licence number of each well;
- (g) a copy of the document or agreement establishing the amendment between the royalty interest owners and/or the working interest owners; and
- (h) a revised list of all oil and gas interest owners and their respective interests in the unit area.

13.22. Solution Mining Report

The operator of a solution mining well shall, on or before the 15th day of February in each year, make a report in duplicate to the Ministry in Form 5 (Annual Report of Solution-Mined Salt Production) in respect of the preceding calendar year.

13.23. Tests, Logs, Surveys

A salt solution mining operator shall submit the results of all tests, logs and subsidence surveys within 30 days of their completion.

13.24. Spill or Subsidence Occurrence

A salt solution mining operator shall contact **the** Ministry immediately in case of a:

- (a) subsidence event;
- (b) change in the rate of subsidence; and
- (c) brine spill.

Part 14. Historical Oil Field Standards

Where other publications are referenced within this Part, the reference shall be read as a reference to the most current edition of the publication in effect, including all published amendments.

The following standards shall apply to oil field production operations having historical oil field status. Where conflict arises between this Part and other Parts of the Standard this Part shall prevail with respect to historical oil field status operations only. This section does not apply to:

- (a) any well drilled after January 1, 1980;
- (b) any new works added to an oil field with historical status;
- (c) a historical oil field without historical oil field status; or
- (d) an oil field with historical oil field status that has ceased production for 24 or more months after it has been registered with the Ministry.

14.1. Definitions

“historical oil field” means an oil field that is:

- (a) part of the Bothwell-Thamesville, Oil Springs or Petrolia fields; and
- (b) produced from wells drilled to a depth less than 200 metres into formations of Devonian age.

“historical oil field status” means an oil production operation:

- (a) located in a historical oil field;
- (b) still producing oil on December 31, 1996; and
- (c) registered with the Ministry by December 31, 1997.

14.2. Underground Storage Tanks

Where an underground tank is installed, the operator shall:

- (a) construct a dike surrounding the tank that is capable of containing any overflow from the tank;

- (b) prevent access to the tank by:
 - (i) constructing and maintaining a cover on the tank and construct such covers in accordance with floor and roofing load requirements of the **Building Code** and provide adequate ventilation; or
 - (ii) constructing a chain link fence 152 cm in height, completely surrounding the tank at a perimeter that is setback 2 meters from the edge of the tank and of adequate construction to prevent access to the tank; and
- (c) install a ladder securely fixed in a vertical position inside the tank with rungs no greater than 15 centimetres from the wall and spaced at regular intervals and extending to the lowermost fluid level in the tank; and
- (d) install a prominent warning sign on the fence or cover, as the case may be.

14.3. Oil Field Fluid Storage

Where formation water is stored in an earthen pond, pit or underground tank the operator shall:

- (a) ensure that the fluid cannot create or constitute a hazard to public health or safety, run into or contaminate any fresh water horizon or body of water or run over or damage any land, road, building or structure;
- (b) ensure that any pond, pit or tank does not leak into the surrounding soil and is suitable for the fluid being stored;
- (c) construct a chain link fence 152cm in height that completely surrounds the pit, pond or tank at a perimeter that is setback 2 metres from the edge of the pit, pond or tank, and is of adequate construction to prevent access to the pit, pond or tank;
- (d) construct any gates on the fence to a height of 152 centimetres and ensure that they are closed and locked;
- (e) install prominent warning signs on all gates and at regular intervals on the perimeter fence;
- (f) install for every pond, a platform, ladder, or other means of safe egress; and
- (g) install rescue and life-saving equipment such as poles, safety rings, and flotation devices inside the fenced area of every pond, and this equipment shall be clearly visible and readily accessible at all times.

14.4. Well Servicing

An operator of a well being serviced shall ensure that a diverter valve and piping are installed on the well prior to being serviced and connected to proper containment to prevent any fluids flowing onto the surface.

14.5. Suspended Wells

The operator of a suspended well shall:

- (a) cap it at surface; and
- (b) permanently mark the site with a steel post with an attached well name sign and maintain such sign; but
- (c) where the well is capable of flow to surface, it shall not be left suspended and the well shall be plugged

Part 15. Glossary

Abandoned well - a well whose use has been permanently discontinued and has been plugged.

Annulus - the space between two casings, between a casing and the tubings or between the casing and the adjacent formations.

Aquifer - any stratum or zone below the surface of the earth capable of producing water from a well.

Blowout - the uncontrolled flow of oil, gas or water from a geological formation that a drilled hole has penetrated.

Blowout Preventer (BOP) - a stack or assembly of valves and equipment attached to the top of the casing during drilling or workover operations to control well pressure.

Bottomhole - the lowermost portion of the well.

Brine - saline water naturally occurring in porous sedimentary rock formations; fluid resulting from the dissolution of salt formations with fresh water for the purposes of salt solution mining.

Brine Well - a well used for dissolving salt from a salt formation, adding brine to, or taking brine from a salt cavern.

Brining (solution mining) - the process of dissolving salt formations using fresh water pumped and circulated into and through wells for the purposes of salt solution mining.

Cable Tool Drilling - a method of drilling where a heavy metal bit is repeatedly raised and dropped to fracture rock by percussion, thereby drilling a well.

Casing - metallic or non-metallic pipe placed in the bore hole for the purpose of supporting the sides of the bore and to act as a barrier preventing subsurface migration of fluids out of or into the bore hole e.g. protection of fresh water zones.

Conductor Casing or Drive Pipe - the initial pipe, usually metallic, used to seal off near-surface or shallow water, prevent the caving or sloughing of overburden into the hole, and as a conductor of the drilling mud through

Oil, Gas and Salt Resources of Ontario, Provincial Operating Standards

loose, unconsolidated shallow layers of sand, clays, and shales into the well bore.

Surface Casing - a string of pipe installed into the bore hole, usually metallic and the first string of pipe run into bedrock and cemented in place.

Intermediate Casing - a string of pipe installed into the bore hole inside the surface casing and cemented in place. The length of the intermediate casing is such that it serves to seal-off any fluid bearing zones, secondary production zones or incompetent rock formations prior to drilling into the target zone. It is also used for the purposes of well control and blowout preventers are installed on it prior to drilling ahead into the target zone.

Production Casing - a pipe, usually metallic, placed into the borehole and cemented into place inside intermediate casing. The length of the production casing is such that it ends at, or into the producing formation or the storage zone.

Casing Inspection Log - a log or combination of logs which:

- (a) determines the percent penetration of anomalies;
- (b) distinguishes between external and internal corrosion; and
- (c) detects holes, pits, perforations, metal loss and metal thickness.

Casing Shoe - a reinforcing collar of steel screwed onto the bottom joint of casing to prevent abrasion or distortion of the casing as it forces its way past obstructions on the wall of the bore hole.

Cathodic Protection - an electro-chemical, anti-corrosion technique for protection of metal structures such as well casings, pipelines, tanks, buildings whereby weak electric currents are set up to offset the current associated with metal corrosion.

Cementing - the operation whereby a cement slurry is pumped and circulated down a well through the center of the casing and then upwards into the annular space behind the casing in order to firmly fix the casing in the hole and to buttress the casing string from formation, production or injection pressures and to protect the casing from corrosion due to exposure to formation fluids.

Centralizer - a casing accessory installed on the outside of a casing string to center the casing string inside the borehole or larger casing;

Oil, Gas and Salt Resources of Ontario, Provincial Operating Standards

Communication - the passage of hydrocarbons or waters through porous and permeable connections from one reservoir to another in a single formation; from formation to formation; or from any formation to any ground water aquifer or to the surface;

Connate Water - water trapped within the interstices of a sedimentary rock at the time the rock was deposited.

Drill Sump or Pit - an excavation below ground level, constructed for the purpose of circulating drilling fluids during well drilling operations.

Drilling Mud - a mixture of clay, water and chemical additives circulated into a well bore during the drilling a well by injection in the drill pipe and through the drill bit to control formation pressure, to lubricate the drill pipe, keep the drill bit cool and to transport the drilled material to the surface.

Flow Rate - the volume measure of the flow of a fluid per unit of time through an orifice, pump, turbine, conduit or channel.

Fluid - any material or substance which flows or moves and which is in a semisolid, liquid, sludge, or gas state.

Formation - a body of rock characterized by a degree of homogeneous lithology that forms an identifiable geologic unit that can be mapped on the earth's surface or is traceable in the subsurface.

Fracturing - a method of stimulating production or improving deliverability from a formation by inducing fractures and fissures in the formation by applying an external force either through hydraulic pressure or explosive force to the face of the target formation.

Fracture Gradient - the pressure gradient, if applied to subsurface formations, will cause the formations to physically fracture.

Gradient (operating) - the pressure gradient (pressure at casing seat/metre of overburden) existing during cavern operation and is a function of the mode of operation (brine/hydrocarbon injection/withdrawal), the rate of fluid injection or withdrawal and its relative density and the tubing/casing string sizes.

Gradient (pressure) - the ratio of pressure per unit depth.

Injection Well - a well into which fluids other than the fluids associated with active drilling operations are being injected

Liner (casing) - casing installed within production casing normally for remedial repairs.

Lithology - the study or characterization of rock formations.

Neat Cement - is cement that does not contain any extenders or density reducing additives that affect the curing time and compressive strength of the cement.

Overburden - loose or unconsolidated sediments, which overlie lithified rock formations.

Packer - an expanding plug used in a well to seal off certain sections of the tubing or casing when cementing, acidizing, or when a production formation is to be isolated. Packers are run on the tubing or the casing, and when in position can be expanded mechanically or hydraulically against the pipe wall or the wall of the well bore.

Permeability - the degree of connectivity of the pore spaces within reservoir rock which facilitates the movement of fluids through it; a measure of the rock's capacity to transmit fluids.

Porosity - the state or quality of being porous; the volume of the pore space within a formation expressed as a percent of the total volume of the rock mass containing the pores.

Preflush - one or more separate volumes of fluid that are pumped ahead of the cement as a compatible buffer between the cement and drilling fluid and to clean the drilling mud from the annulus in preparation for cementing.

Reservoir - a porous, permeable sedimentary rock formation containing quantities of hydrocarbons enclosed or surrounded by layers of less permeable or impervious rock; a structural trap; a stratigraphic trap.

Rotary Drilling - drilling a borehole for a well with a drill bit attached to joints of hollow drill pipe which are rotated to accomplish penetration of rock formations.

Salt Formation - a rock formation comprised of predominantly sodium chloride deposits which is generally impervious to liquid or gaseous hydrocarbons, has

Oil, Gas and Salt Resources of Ontario, Provincial Operating Standards

compressive strength comparable to that of concrete, moves plastically to seal fractures or voids, and can be easily mined by dissolution with water.

Salt Cavern - a cavern constructed within a soluble rock formation, commonly rock salt, by circulating fresh water in a controlled manner for the purposes of creating an underground hydrocarbon storage chamber.

Salt Dome - a domed-shaped incursion of salt into overlying formations caused by low-density salt deposits rising through higher density formations overlying the salt deposit.

Shoe Joint - a short section of casing, usually the bottom joint of the string, bounded by the casing shoe and the float collar which is used to contain the tail end cement slurry.

Shut-in Pressure - the pressure recorded at the wellhead or subsurface when valves are closed to shut-in the flow from or injection into the well.

Solution Mining - the process of injecting fluid through a well to dissolve rock salt or other readily soluble rock or mineral and production of the artificial brine so created.

Spud - with respect to a well, means the commencement of actual drilling of the well's surface casing hole using a cable tool or rotary drilling rig, but does not include activities to prepare a site for drilling the well, including the installing of conductor pipe.

Stimulate or Stimulation - the treating of a well bore by any chemical or mechanical method such as acidizing, fracturing, perforating or solvent treatment to increase production, injection or recovery of oil, gas, brine or any other substance.

TD Date - means the date when the drilling of a well reaches the total depth of the well.

TD - the total depth of a well.

SCHEDULE 1 – Drilling BOP Requirements

SCHEDULE 1

BLOWOUT PREVENTION SYSTEMS

EQUIPMENT CODE

R – single ram type preventer with one set of rams, either blank or for pipe.

A – annular-type blowout preventer.

S – drilling spool with flanged side outlet connections for bleed-off and kill lines.

METRIC SYMBOLS

m – metre

mm – millimetre

kPa – kilopascal

EQUIPMENT SYMBOLS



Nitrogen Reserve



Accumulator

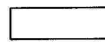

Hydraulic Oil Reservoir



Charge Pump



Flanged Valve



Screwed Valve



Hydraulic Valve



Adjustable Choke



Hydraulic Choke



Bull Plug



Pressure Gauge



Flow Direction

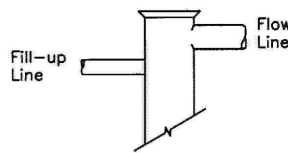

Flow Tee

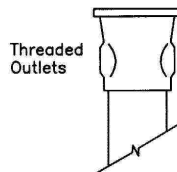

Threaded Outlets

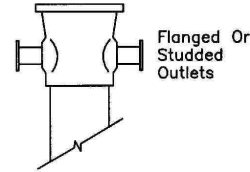

Flanged Or Studded Outlets

Casing Bowls

SCHEDULE 1

DRILLING BOP SYSTEMS – CLASS A (CABLE TOOL)
FOR WELLS WITHOUT 1st CONTROL STRING SET

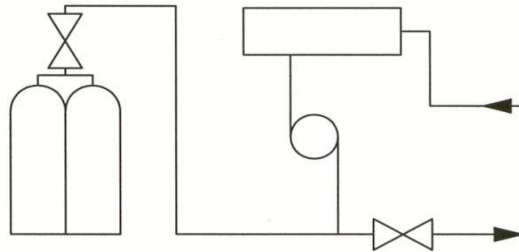

HYDRAULIC CONTROL SYSTEM
(FOR BLIND RAM OR ANNULAR)

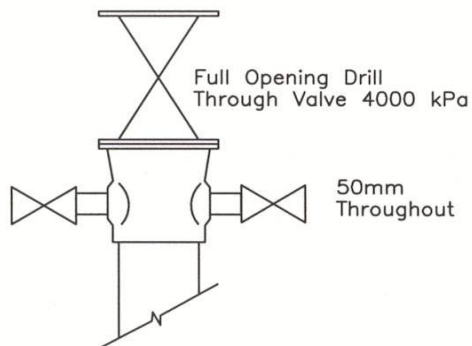

OR

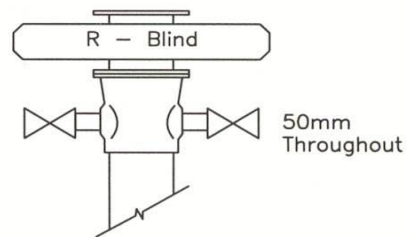

SCHEDULE 1

DRILLING BOP SYSTEMS – CLASS A (ROTARY)
FOR WELLS WITHOUT 1st CONTROL STRING SET

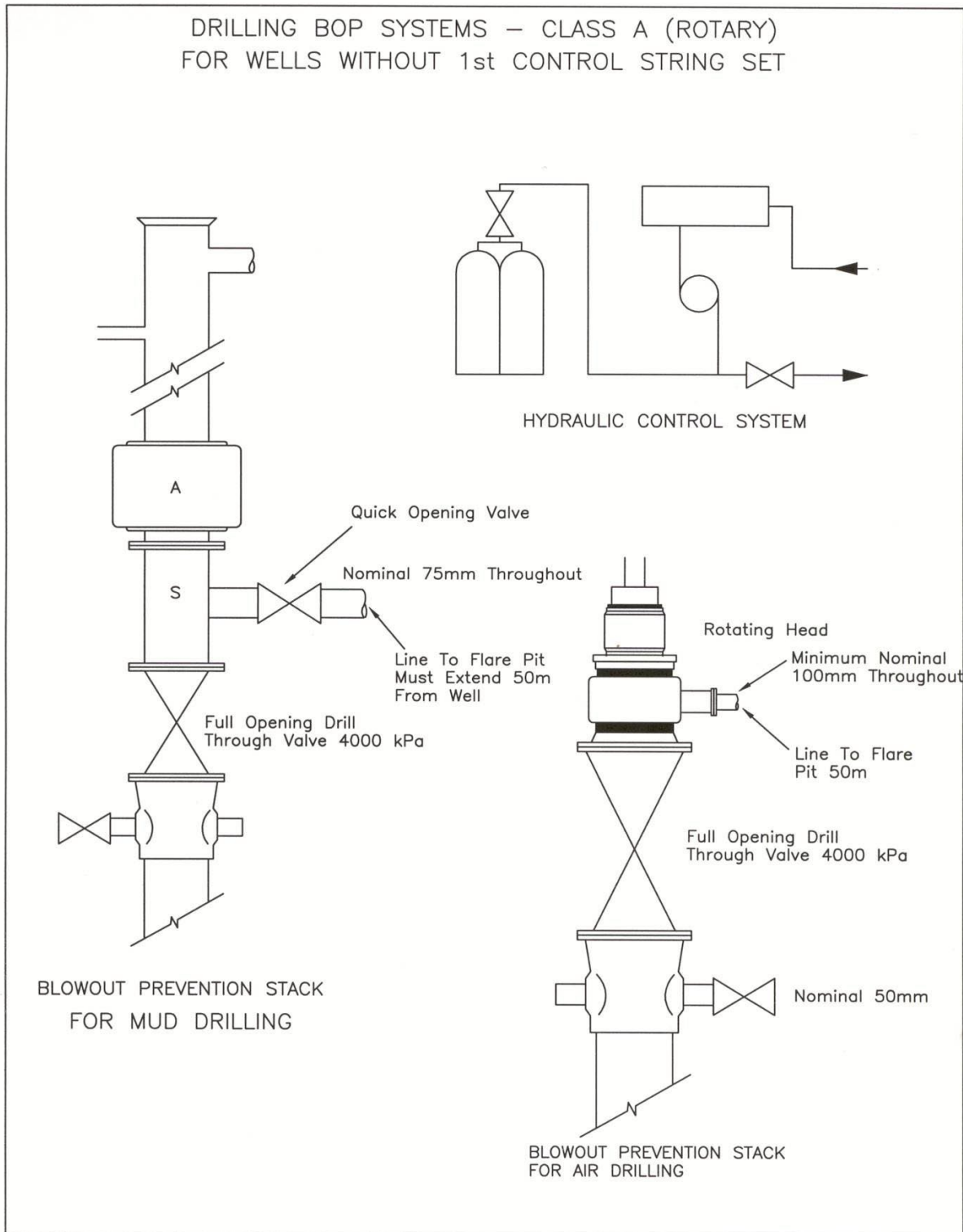

SCHEDULE 1

DRILLING BOP SYSTEM CLASS B (CABLE TOOL)
FOR WELLS WITH 1st CONTROL STRING SET

MINIMUM PRESSURE RATING 14,000kPa

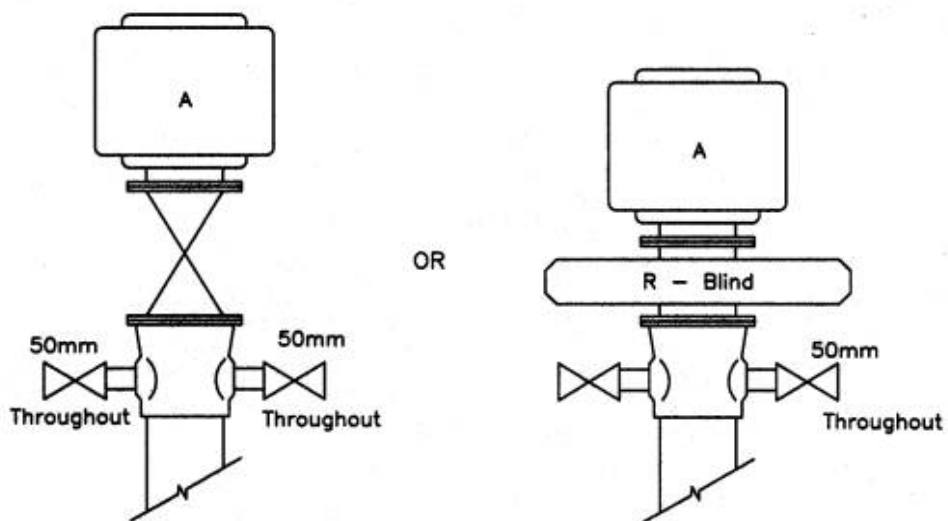

NOTE:

1. The first control string of casing shall be set and cemented prior to drilling into the target zone.

SCHEDULE 1

DRILLING BOP SYSTEMS – CLASS B (ROTARY)
FOR WELLS WITH 1st CONTROL STRING
WITHOUT EXCEEDING A DEPTH OF 1800 m
MINIMUM PRESSURE RATING 14,000kPa

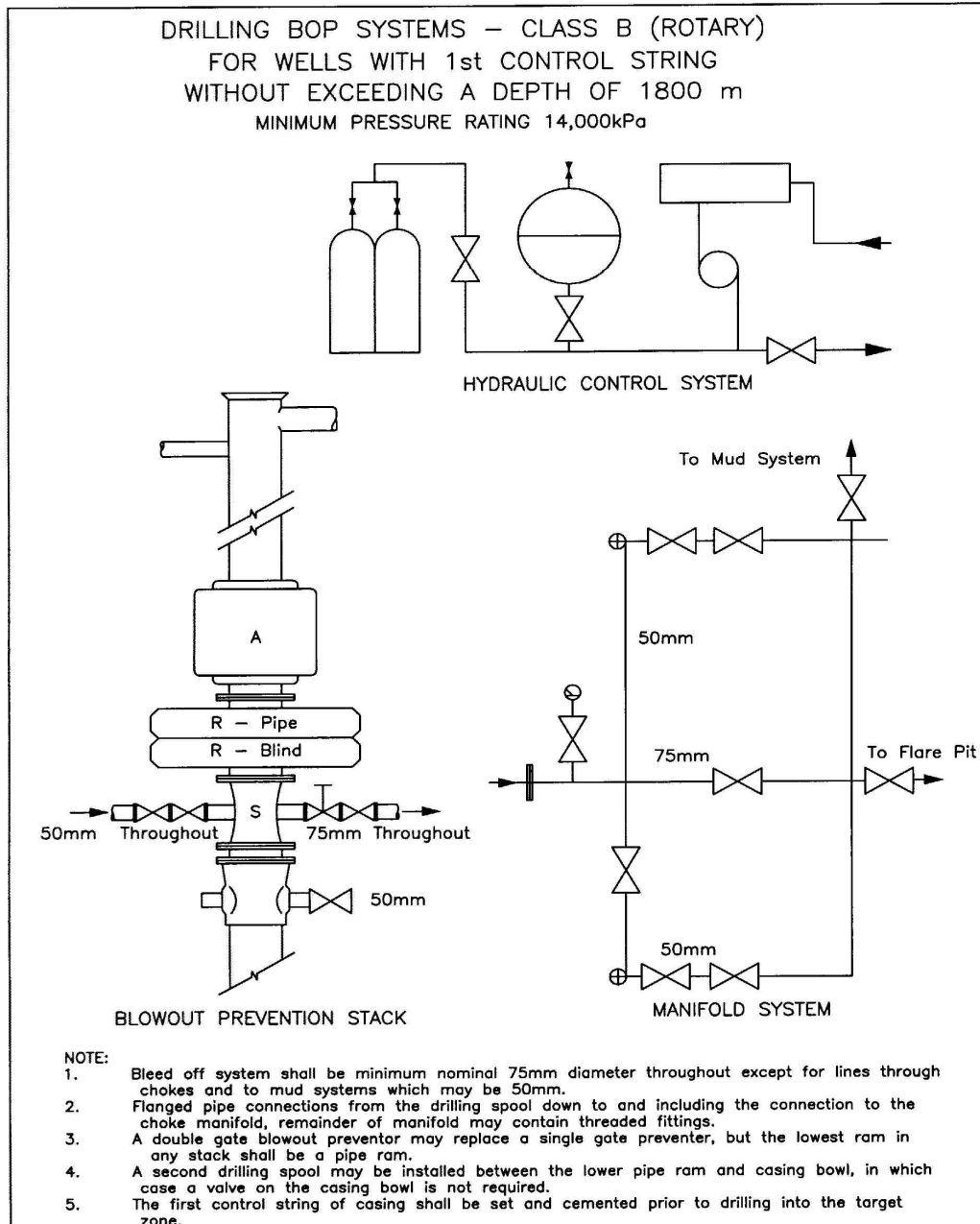

SCHEDULE 2 – Well Servicing BOP Requirements

SCHEDULE 2

CLASS I
RESERVOIR PRESSURE LESS THAN 5500 kPa AND NO H₂S PRESENT

MINIMUM PRESSURE RATING 14,000kPa

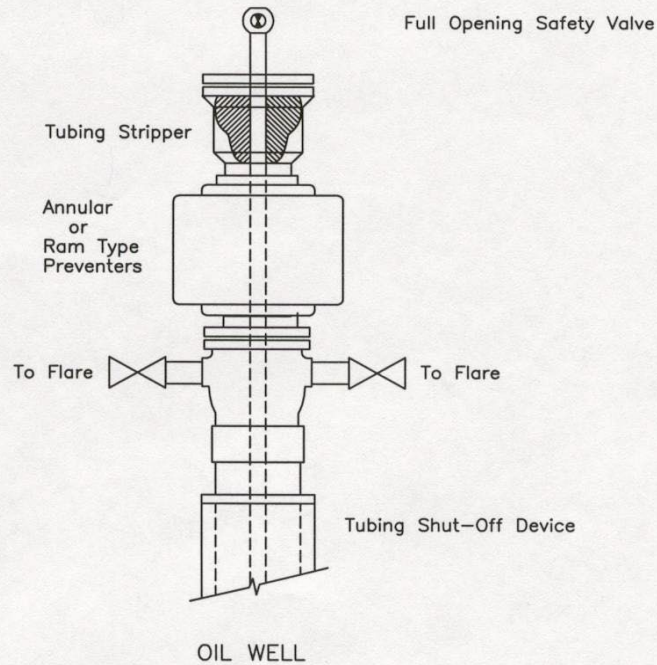
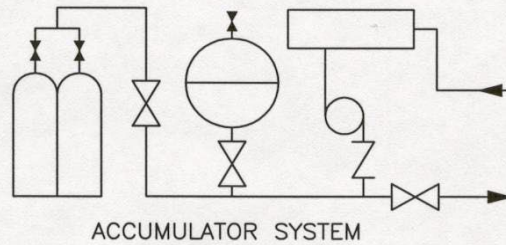

BLOWOUT PREVENTION STACK

NOTE:

1. Well is not killed.
2. A tubing and blind ram blowout preventer unit may be used in lieu of an annular preventer (position of rams may be interchanged).
3. The Tubing stripper may be located below the blowout preventer(s) provided it is an integral part of the wellhead.
4. Two Flare Lines – minimum diameter 50 mm, or
One Flare Line – minimum diameter 75 mm, extending 50 m from well.

SCHEDULE 2

CLASS II

RATING OF PRODUCTION CASING FLANGE IS LESS THAN OR EQUAL TO 21,000kPa

H₂S CONTENT OF THE GAS IS LESS THAN 10 moles/kilomole

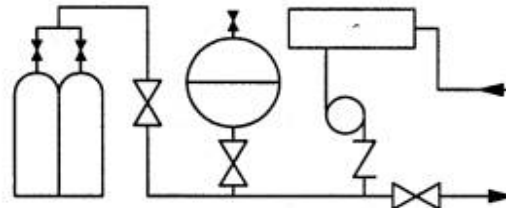

ACCUMULATOR SYSTEM

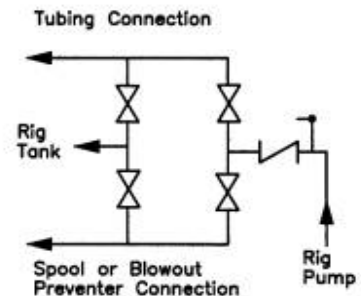
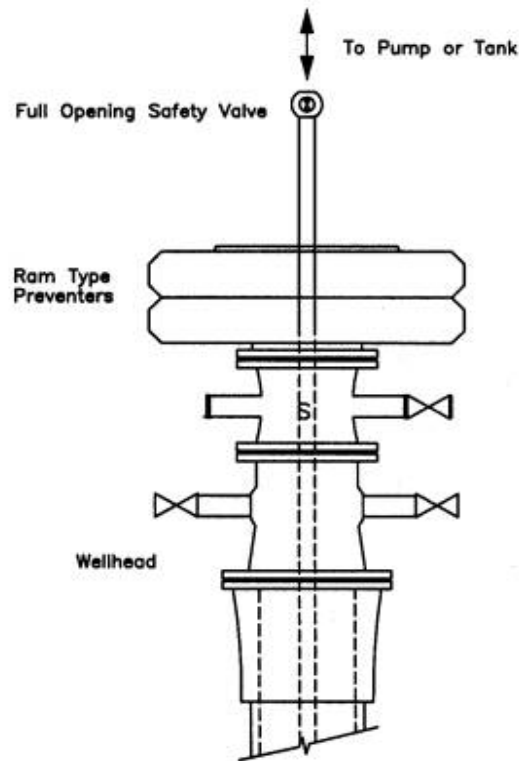

MANIFOLD SYSTEM

BLOWOUT PREVENTION STACK

NOTE:

1. Pressure rating of preventers is equal to or greater than the production casing flange rating, or the formation pressure, whichever is the lesser.
2. 50 mm lines throughout.
3. The positioning of the tubing and blind rams may be interchanged.
4. Spool may have threaded side outlet (and valve) if wellhead has threaded fittings.
5. A flanged blowout preventer port (and valve) below the lowest set of rams may replace spool (valve may be threaded if wellhead has threaded fittings).

SCHEDULE 2

CLASS III

1. RATING OF PRODUCTION CASING FLANGE IS GREATER THAN 21,000 kPa, OR
2. RATING OF PRODUCTION CASING FLANGE IS LESS THAN OR EQUAL TO 21,000 kPa and H₂S CONTENT OF THE GAS IS EQUAL TO OR GREATER THAN 10 moles/kilomole

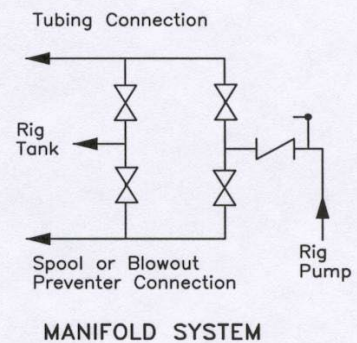
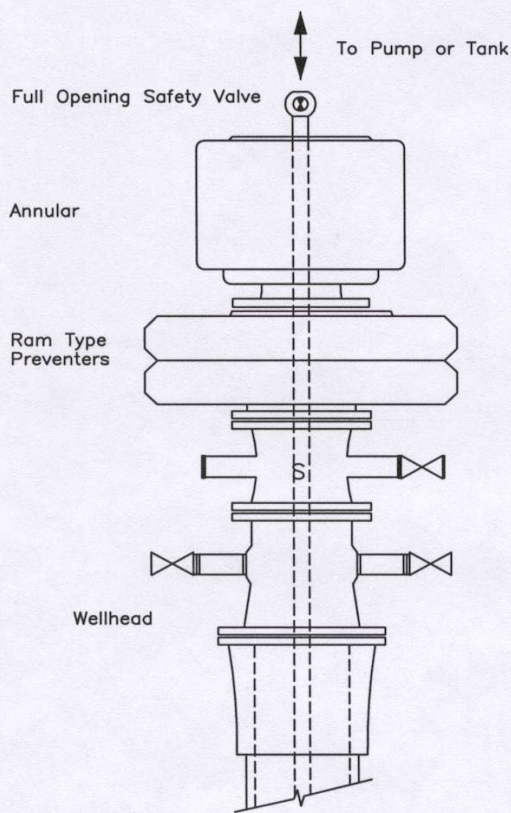
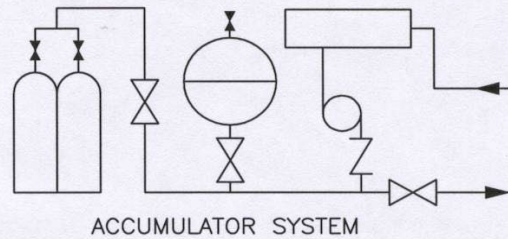

BLOWOUT PREVENTION STACK

NOTE:

1. Pressure rating of preventers is equal to or greater than the production casing flange rating, or the formation pressure, whichever is the lesser.
2. 50 mm lines throughout.
3. The positioning of the tubing and blind rams may be interchanged.
4. Spool may have threaded side outlet (and valve) if wellhead has threaded fittings.
5. A flanged blowout preventer port (and valve) below the lowest set of rams may replace spool (valve may be threaded if wellhead has threaded fittings).

Figures 1-4

Figure 1

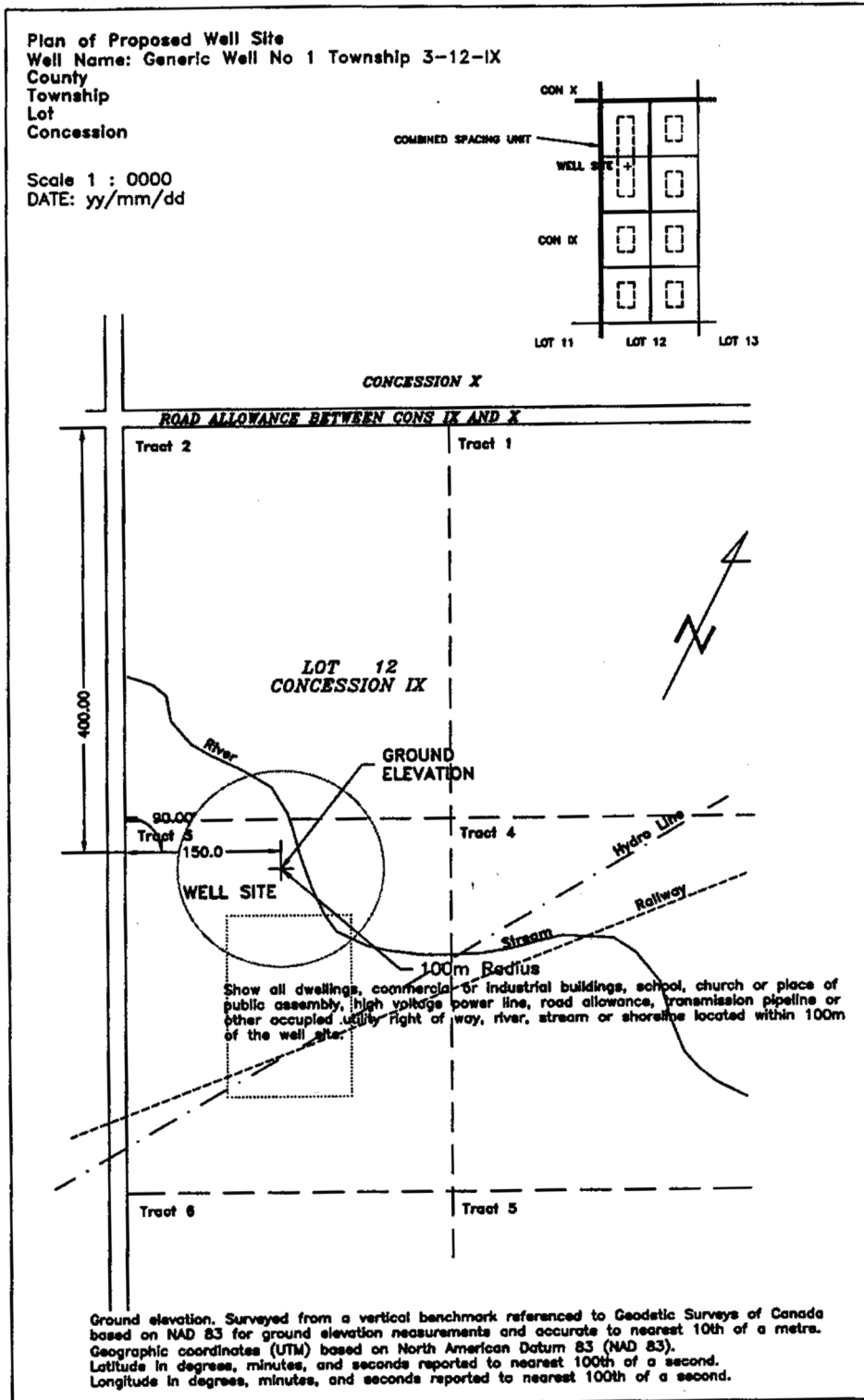

Figure 2

EQUIPMENT SPACING – WELL SERVICING REQUIREMENTS

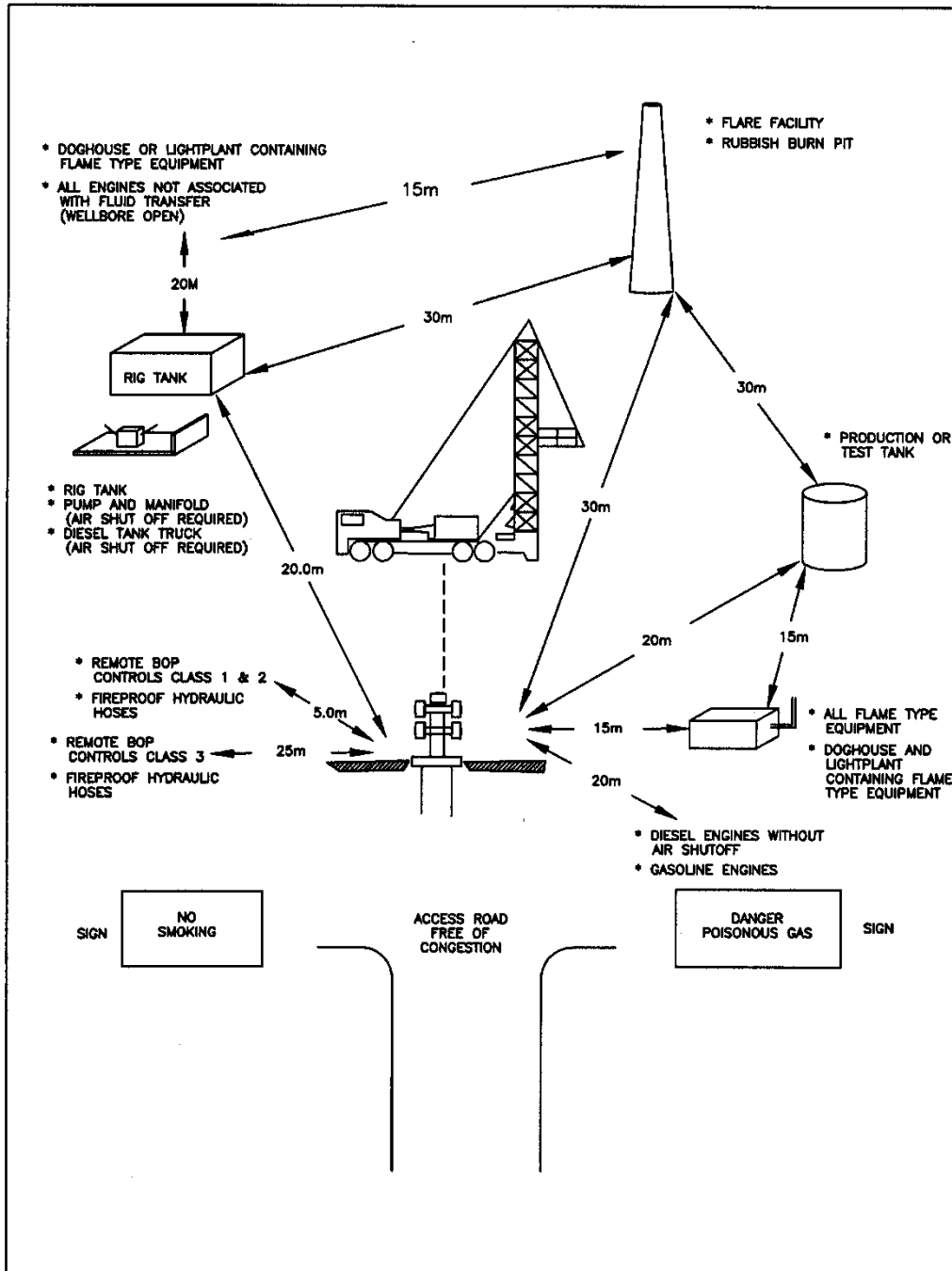

Figure 3

OILFIELD BRINE DISPOSAL WELL CONSTRUCTION

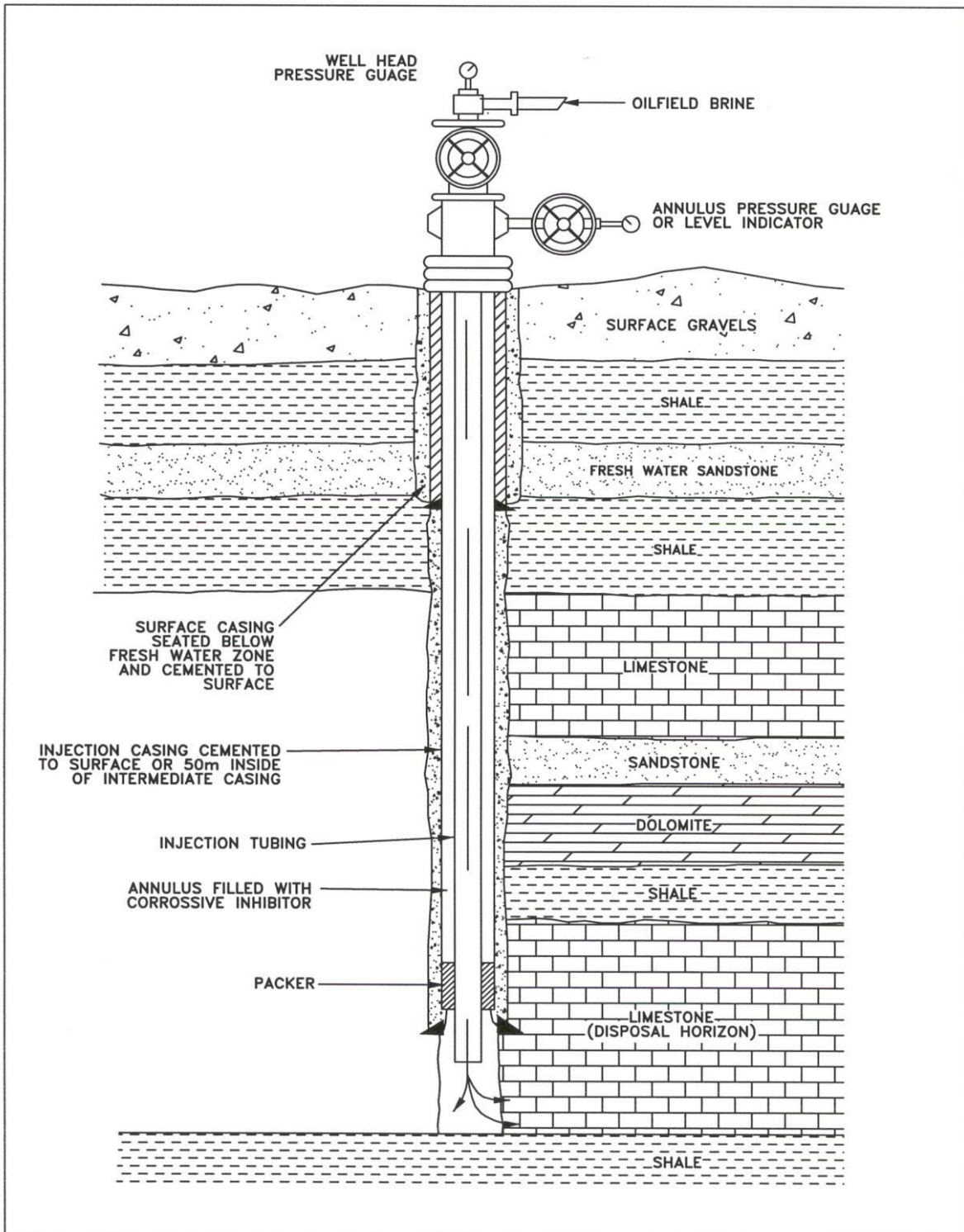

Figure 4

TYPICAL SALT SOLUTION MINING — SINGLE CAVERN

